

WATER

GENERAL

CONSTRUCTION

SPECIFICATIONS

AND

DETAILS



CITY OF CONOVER
PUBLIC UTILITY
DEPARTMENT

REVISED:
OCTOBER 2025

Note: *All Drawings are not engineer stamped drawings*
General Construction Specifications and Details for Water may be modified by the City at any time.

Table of Contents

Section 1 — General Requirements

Page No.	Article	
5	1.0	Maintenance of Traffic and Access to Residences
5	1.1	Working in State Highway Right-of-Way
5	1.2	Protection and Restoration of Property
6	1.3	Protection of Existing Utilities
6-7	1.4	Trench and Backfill
7	1.5	Trench and Stabilization
7	1.6	Preconstruction Conference
7	1.7	Construction Conferences
8	1.8	Clean Up
8	1.9	Final Inspections

Section 2 — Water Materials Specifications

8-9	2.0	Water Pipe
9	2.1	Encasement Pipe
10	2.2	Water Pipe Fittings
11	2.3	Mechanical Joint Restraints
11-13	2.4	Valves and Tapping Sleeves
13	2.5	Fire Hydrants
13-14	2.6	Water Laterals and Appurtenances

Section 3 — Installation of Water Pipe

15-16	3.0	Installation of Water Pipe
16-17	3.1	Valve and Fitting Installation
18	3.2	Tapping Sleeve and Valve Installation
18-19	3.3	Hydrant Installation
19-20	3.4	Blow-Offs
20	3.5	Water Service Laterals
20-23	3.6	Pressure Testing and Chlorination of Water Lines

Section 4 — Backflow Protection

23	4.0	Backflow Protection
----	-----	---------------------

Engineering

24		Average Daily Water Demands
25-28		Sizing Water Service Lines and Meters
29		Engineers Certificate of Completion

30	Contractors Certificate of Completion
31	Submittal of Potable Water Distribution Data Sheet

Typical Design Details

33	Ownership of Water Lines
34	Standard Placement of Sewer in Street Section
35	(std 100W) Typical 3/4" Water Service Connection
36	(std 101W) Typical 1" Service Connection
37	(std 102W) Typical 1" Service Connection Serving 2 Meters
38	(std 103W) Meter Box Detail - 3/4" x 5/8" and 1"
39	(std 104W) Typical 2" Water Service Connection
40	(std 105W) 2" Water Service Connections Backflow Locations
41	(std 106W) 2" Water Service Installation, Backflow in Box
42	(std 107W) 2" Water Service Installation, Backflow in Building
43	(std 108W) 2" Water Service Installation, Backflow in Box
44	(std 109W) Water Line Trench
45	(std 110W) Tracer Line Detail
46	(std 110W-1) Tracer Line Detail
47	(std 111W) Standard Hydrant Lateral
48	(std 112W) Below Ground Flush Type Blow-Off Detail
49	(std 113W) Below Ground Blow-Off Hydrant
50	(std 114W) Below Ground Blow-Off Hydrant
51	(std 115W) Thrust Blocking Detail
52	(std 116W) Lowering Water Main
53	(std 117W) Deadman Detail
54	(std 117W-a) Thrust Collar & Blocking
55	(std 117W-b) Rod Anchors Datum Chart
56	(std 118W) Markings for Water/Sewer Services

Typical Design Details

57	(std 200W) Underground Meter Vault 3" and Larger
58	(std 201W) Underground Meter Vault 3" and Larger

Typical Design Details

59	(std 300WB) 3/4"- 2" Reduced Pressure Back-Flow Preventer Above Ground
60	(std 301WB) 3"- 8" Reduced Pressure Back-Flow Preventer Above Ground
61	(std 302WB) 3/4" - 8" Reduced Pressure Back-Flow Preventer Below Ground
62	(std 303WB) 3/4" - 1" Double Check Valve Assembly
63	(std 304WB) 1 1/2" - 2" Double Check Valve Assembly
64	(std 305WB) 3" - 8" double Check Valve Assembly

Typical Design Details (cont.)

65	(std 306WB)	Sprinkler Vault
66	(std 307WB)	Back-Flow Prevention Tanker Trucks (Air Gap)
67	(std 308WB)	Temporary Jumper Connection

1.0 MAINTENANCE OF TRAFFIC AND ACCESS TO RESIDENCES

The Contractor shall maintain traffic in accordance with all applicable provisions of Section 150 of the most current edition of the "Standard Specifications for Roads and Structures" published by the NCDOT and the following provisions. The Contractor shall provide and maintain adequate barricades, signal lights, flagger and other warning devices for the protection of traffic in conformance with the current edition of the "Manual on Uniform Traffic Control Devices for Streets and Highways" published by the FHWA. If, during the progress of a project, bad weather forces a delay of construction, the Contractor shall maintain in a safe and practical way the roadways used by the public or individuals so that neither may be unnecessarily delayed or inconvenienced on account of the work being carried on by the Contractor, the Contractor shall bear all costs associated with maintaining public traffic and access to individual residences to the satisfaction of the Engineer. This shall include, but is not limited to, the use of street maintenance stone. The Contractor shall indemnify and save harmless the City and all its officials, agents, employees, from all suits, actions, or claims of any character, name or descriptions brought for or on account of any injuries or damages received or sustained in consequence of any neglect in maintaining traffic as specified. No direct payment will be made for maintaining traffic as the cost of same shall be included in the contract prices for the various pay items.

1.1 WORKING IN STATE HIGHWAY RIGHT-OF-WAY

The Contractor shall adhere to the most current edition of the "Policies and Procedures for accommodating Utilities on Highway Rights of Way" published by the NCDOT when construction is performed within the State Highway right-of-way. Permits will be obtained by the City for installations in the highway rights-of-way; however, the Contractor shall notify the NCDOT prior to beginning work in said rights-of-way, provide, place, and maintain barricades, signs, danger lights, and other safety devices as required by the Department.

1.2 PROTECTION AND RESTORATION OF PROPERTY

The Contractor shall be responsible for the protection from their activities of all public and private property on and adjacent to the work and shall use every reasonable precaution necessary to prevent damage to pipes, conduits, and other underground structures, and to trees, poles, wires, cables, and other overhead structures. The Contractor shall protect carefully from disturbance or damage all land monuments and property markers until the Engineer has witnessed or otherwise referenced their location and shall not remove them until directed. The Contractor will be held responsible for all damage or injury to property of any character resulting from any act, omission, negligence, or misconduct in the prosecution of the work. When any direct or indirect damage or injury is done to public or private property by or on account of any act, omission, negligence, or misconduct in the execution of the work, the Contractor shall either restore at his/her own expense such property to a condition similar or equal to that existing before such damage or injury was done, or shall make good such damage or injury in a manner acceptable to the owner of the damaged property and to the City. In case of failure on the part of the Contractor to restore such property or make good such damage or injury the City may, at the Contractor's expense, repair, rebuild, or otherwise restore such property in such manner as the Engineer may consider necessary.

1.3 PROTECTION OF EXISTING UTILITIES

Reasonable care has been exercised in showing the location of existing utilities on the Plans. The exact location of such utilities is not known in all cases. The Contractor shall explore, at his own expense, the area ahead of ditching operation by observation, electronic devices, and by personal contacts with the utility companies, and locate such utilities in advance of the trenching operations, and shall conduct his work so as to eliminate or minimize damage to the existing structures or utilities. The Contractor shall be held responsible for any damages resulting from not exploring the area ahead, negligence, careless operations on his part, or damages to existing pipe, wire, structures, etc. All construction must conform to the underground utility protection act of North Carolina. **BEFORE YOU DIG! CONTACT ONE-CALL CENTER at 811 or 1-(800)-632-4949** as shown on the plans.

Utility lines, such as telephone and electric, should be moved if possible to the proper location to the extent practical by others before the Contractor commences work.

1.4 TRENCH AND BACKFILL

A. Description:

*The work covered by this Article consists of excavating, backfilling, compacting, and cleaning up a trench for water lines.

B. Construction Requirements:

*The trench shall be excavated to the alignment shown in the drawings or to the centerline staked in the field. The depth of the trench shall conform to the profile shown in the drawings.

*Trench width at the top of the pipe shall not exceed the nominal diameter of the pipe plus two feet without approval of the Engineer.

*Trench sheeting, shoring, or bracing shall be used where shown in the drawings, specified in the Special Conditions, or directed by the Engineer to protect the utility under construction, to allow construction to be performed according to drawings and specifications, or to prevent damage to property. The Contractor shall adhere to all OSHA requirements concerning trench sheeting, shoring, or bracing during all trench excavation. Where trench sheeting, shoring, or bracing is used, the trench width may be increased accordingly.

*Trench protection shall be left in place at least until the pipe has been laid and backfilled to a point two feet above the pipe. The Engineer may direct that trench sheeting be left in place.

*Trench excavation shall proceed in advance of pipe installation for only as far as the Engineer will permit.

*Depressions in the stone bedding for the pipe bells shall be provided at each joint but shall be no larger than necessary for joint assembly and assurance that the pipe barrel will lie flat on the trench bottom. The trench bottom shall be true and even in order to provide support for the full length of the pipe barrel, except that a slight depression may be provided to allow withdrawal of pipe slings or other lifting tackle.

*Should the trench pass over a sewer or other previous excavation, the trench bottom shall be sufficiently compacted to provide support equal to that of the native soil. Care shall be taken to prevent damage to the existing installation.

*Where the trench subgrade is found to be unstable or to include unsuitable materials, it shall be undercut as described in Sub-Article 1.5, "Trench Stabilization".

*Trench excavation is classified to include rock only. All other material is unclassified and shall be excavated under the provisions of this Article. Excavated material shall be placed in a manner that will not obstruct the work, endanger the work or otherwise cause a threat to the welfare of the public. The trench shall be kept dewatered during the excavating, pipe laying and backfilling stages of the work. Discharge from any dewatering pumps shall be conducted to natural drainage channels, storm sewers, or an approved reservoir.

*All backfill material shall be free from cinders, ashes, vegetable or organic material, boulders, rocks or stones, frozen soil, or other material that, in the opinion of the Engineer, is unsuitable. When the type of backfill material is not indicated in the drawings or is not specified, the excavated material may be used, provided that such material consists of loam, clay, sand, gravel, or other materials that, in the opinion of the Engineer, are suitable for backfilling.

*Backfill material around the pipe and to a point 1 foot above the barrel of the pipe shall be selected materials that can be compacted to form a dense envelope about the pipe. All backfill material from the trench bottom to the top shall be compacted to a density of 95% of Standard Proctor Density. The Contractor shall be responsible for all settlement over trenches that may occur prior to the completion of his contract and for a period of twelve months thereafter.

*Particular attention will be directed to inspection of the material envelope around pipe designed as a flexible conduit. All excess trench excavation shall be disposed of in an approved waste area. Any deficiency in backfill material shall be provided by the Contractor except in cases where payment is authorized for replacement backfill material. The grounds surface shall be left in a condition such that erosion control measures can be immediately carried out.

1.5 TRENCH STABILIZATION

A. Description:

*The work covered by this Article consists of undercutting and stabilizing trench bottoms with crushed stone.

B. Construction Requirements:

*Where the sub grade is found to be unstable or to include ashes, cinders, refuse, organic material, or other unsuitable material, such material shall be removed to a minimum of 3- inches, or to the depth ordered by the Engineer, and replaced under the directions of the Engineer with either No. 57 or 67 stone. The locations for trench undercutting, and the amount of stone to be used by the Contractor shall, in all cases, be designated by the Engineer.

1.6 PRECONSTRUCTION CONFERENCE

*A preconstruction conference will be held after award of the proposed work. The date for this conference is to be established immediately after award of the project.

1.7 CONSTRUCTION CONFERENCES

*After work on the contract has begun, construction conferences are to be held periodically. The construction conferences are to be scheduled at times that are mutually agreeable to the Contractor or the Representative and the Engineer. It shall be the responsibility of the Contractor or the Representative to attend the conferences.

1.8 CLEAN-UP

*During construction of the project, the Contractor will maintain the work area and adjacent streets in as neat a manner as can be reasonably expected. In the event that adjacent streets need to be cleaned or flushed due to negligence by the Contractor, the Contractor will be responsible for seeing that this work is done. Street cleaning services will not be provided by the City free of charge.

*For street and utility projects, this shall include, but not be limited to; cleaning all area disturbed right-of-way's, shoulders, streets, utility structures, etc. This shall also include removing and disposing of all excess materials, trash, debris, etc. Disturbed areas, between the curb line and limits of grading, shall be hand raked and all brick, mortar, rock, clods, and other debris shall be removed and disposed of. It shall further be the Contractor's responsibility to maintain all areas disturbed until final acceptance of the project by the City.

1.9 FINAL INSPECTIONS

*When the Contractor has a project ready for final inspection, he will inform the Engineer in writing and a date will be set up for said final inspection. The Engineer or his representative will meet with the Contractor's representative, and they shall make a thorough inspection of the job. The Contractor shall furnish all labor necessary to open and inspect all manholes, catch basins, and valve boxes. A list of all deficiencies shall be made and the Contractor must correct them before acceptance of the construction portion of the project by the City.

*On street and utility projects, the Contractor will insure that all structures are clear and free of debris and all valve boxes shall be clean, such that valve wrench can make solid contact with the operating nut prior to the above mentioned final. Miscellaneous brick, mortar, stone, asphalt, concrete or other debris shall be removed from the project and disposed. Hand raking of yards will have taken place and all seeding, mulching and erosion control completed. All meter boxes, cleanouts or other structures on the shoulder shall be uncovered and in plain view for the final inspection.

Water Materials Specifications

2.0 WATER PIPE

A. Ductile Iron Pipe :

*At a minimum, ductile iron pipe shall conform to the requirements of AWWA Standard 15 C-151, ASTM A-746 with thickness design conforming to the procedures outlined in AWWA 16 C-150. Unless otherwise shown on the construction plans, all ductile iron pipe shall be 17 furnished with push-on joints in accordance with AWWA C-111 and a cement mortar lining 18 of standard or double thickness in accordance with AWWA C-104.

1. Ductile Iron Pipe 3-inch thru 12-inch:

*Water pipe three inch thru twelve inch nominal diameter shall be ductile iron pipe designed in accordance with AWWA C151/A21.51, ASTM A-746, minimum pressure class 350, with cement mortar lining in accordance with AWWA C104. A higher pipe lass may be required based on installation conditions and as shown on the construction plans and/or elsewhere in Special Provisions.

2. Ductile Iron Pipe 16-inch and Larger:

*Water pipe sixteen inch nominal diameter and larger shall be ductile iron pipe designed in accordance with AWWA C151/A21.51, ASTM A-746, minimum pressure class 250, with cement mortar lining in accordance with AWWA C104. The pipe class selection shall be based on the installation conditions. 30-inch diameter pipe shall conform to the Quality Assurance/Quality Control and Design Criteria sections indicated above. A higher pipe class may be shown on the construction plans and/or elsewhere in Special Provisions.

- a. The pipe class selection for all diameters shall be based on the installation conditions and existing or proposed depth of cover. Special thickness class pipe up to and including thickness class 56 shall be required when specified, based on installation conditions and depth of cover/loading conditions.
- b. The pipe shall contain all product markings required by ASTM A-746 and AWWA C12 151. The minimum pipe markings shall include the weight, class or nominal thickness, casting date. The manufacturer's mark, the country where cast, the production year, and the letters "DI" or "DUCTILE" shall be cast or metal stamped on the pipe, and on pipe sizes 14-inch and larger shall not be less than 1/2-inch in height. All markings shall be clear and legible, and all cast or metal-stamped marks shall be on or near the bell.
- c. DIP pipe shall be manufactured within the North American Continent by an approved manufacturer.
- d. Manufacturers:
 1. DIP shall be as furnished by American Cast Iron Pipe, McWane Cast Iron Pipe, US Pipe Company.

B. PVC Pipe:

*Unless amended on the Construction Drawings or elsewhere in these specifications, all 4-inch, through 8-inch water main pipe may be PVC 1120, (DR 14) in accordance with AWWA C-900. PVC pipe specified must be in compliance with AWWA Standard C900 and /or NSF international, and bear the NSF-pw logos.

*The pipe shall have a minimum Pressure Class of 200 PSI. PVC Pressure Pipe shall be made from white or blue pigmented virgin materials and shall be furnished in lengths of 20 feet. All PVC Water Pipe will be shipped, stored, and strung at the project in such a manner as to be protected from accumulated exposure to sunlight and possible ultraviolet radiation of no more than four (4) weeks.

*2-inch water main pipe shall be PVC 1120 (SDR-13.5 PVC Class 315) and manufactured in accordance with ASTM D-2241. Pipe shall be slip joint with integral bell and gasket meeting AASTM F-477.

***Blue Coated 12 gauge copper tracing wire must be installed with all PVC pipe**

2.1 ENCASEMENT PIPE

*Encasement pipe shall be uncoated steel pipe conforming to the Standards of AWWA C200. Minimum diameter and wall thickness shall be as follows:

<u>Encasement Pipe O.D.</u>	<u>Roadway</u>	<u>Railroad</u>
14"	0.216"	0.250"
16"	0.250"	0.281"
20"	0.250"	0.344"
24"	0.250"	0.375"
30"	0.312"	0.469"
36"	0.375"	0.531"
42"	0.438"	0.625"
48"	0.500"	0.688"

*All carrier pipes installed with joints inside an encasement pipe must utilize restrained joints. (Griffin Mech-Lok, US Pipe MJ Harness-Lok, equivalent). For special installations see drawings for wall thickness.

2.2 WATER PIPE FITTINGS

*Pipe fittings shall be ductile iron designed and manufactured as per ANSI/AWWA C110/A21.10. Fittings shall be designed for an internal pressure of 250 psi.

*Class 350 ductile iron compact fittings may be furnished as an alternate to Class 250 iron fittings.

*Ductile iron material used for Class 350 iron fittings shall conform to ASTM A536, minimum grade 70-50-05. Thickness of Class 350 iron fittings shall be equal to, or exceed, 350 psi working pressure rated ductile iron pipe thickness. Radii or curvatures shall conform to ANSI A21.10. The Class 350 ductile iron compact fittings shall conform to ANSI/AWWA C153/A21.53 and all applicable provisions of this Article. Lining for all pipe fittings shall be cement mortar with a seal coat of bituminous material, all in accordance with ANSI A21.4. All pipe fittings shall have mechanical joints in accordance with ANSI A21.11.

2.3 MECHANICAL JOINT RESTRAINTS

A. Wedge Action Retainer Gland

*Mechanical joint follower gland, with gripping wedge restraint system, incorporated into the design of the gland. Proper torque of the wedges is regulated by twist off nuts. It is used to restrain valves, fittings and hydrants to ductile iron pipe.

Rated Restraint

3" through 16" = 350psi

18" through 36" = 250psi

(Meg-A-Lug series 1100 by EBAA Iron Inc., Stargrip series 3000 by Star Pipe Products, One Lock by Sigma Corporation, equivalent).

B. Mechanical Joint Tee with Restrained Swivel Branch

(For Hydrant Installations)

Used for restraining mechanical joint gate valves directly to the tee.

C. Mechanical Joint Swivel by Mechanical Joint Solid Adapter

*May be used to provide a restrained connection between the outlet side of a mechanical joint gate valve and the mechanical joint connection on a fire hydrant. The length of the adapter shall be as short as possible for the conditions.

*Tees with swivel branch and swivel by solid adapters shall be cement lined with a seal coat of bituminous material in accordance with ANSI/AWWA C104/A21.4 (Tyler Pipe Co., equivalent).

2.4 VALVES AND TAPPING SLEEVES

A. Valves 12-inches and Smaller

*Valves 12-inches and smaller shall be resilient wedge gate valves conforming to the applicable requirements of AWWA C509 Standards, with a working pressure of 250 psi, O-ring sealing, 2" square operating nut, open left and mechanical joint ends. Valves manufactured of ductile iron shall meet all applicable requirements of AWWA C515 with a working pressure of 250 psi. All interior and exterior ferrous metal surfaces shall be coated with a minimum of 8 mils of fusion-bonded coating meeting the requirements of AWWA C550. Valves may be used in sizes 4" thru 12" (Mueller, American Flow Control, M&H, Clow, Kennedy, U.S. Pipe, equivalent).

B. Valves 16-inch and Larger:

*16-inch valves and larger in diameter shall be designed and constructed in such a manner as to include beveled reduction gears to reduce the number of turns and torque require to operate the valves. All roller, tracks and scrapers shall be bronze casting. The resilient wedge gate valve shall conform to the applicable requirements of AWWA C509 Standards with a working pressure of 250 psi, and manufactured of ductile iron. Valves shall have O-ring sealing, 2" square operating nut, open left, and mechanical joint ends (American Flow Control, Clow, U.S. Pipe, equivalent). All interior and exterior ferrous metal surfaces shall be coated with a minimum of 8 mils of fusion-bonded epoxy paint meeting the requirements of AWWA C550.

C. Surge Relief, Pressure Reducing and Altitude Valves:

Surge relief, pressure reducing and altitude valves shall be flanged iron globe body; fully bronze mounted; external pilot operated with free floating piston operated without springs, diaphragm, or levers; single seat with seat bore equal to size of valve. Valves shall be manufactured in accordance with AWWA C506 (Ross, equivalent).

All surfaces of iron castings shall be coated with a minimum of two coats of a serviceable grade of asphaltic base metal paint.

The valve design shall be such that repairs and internal dismantling of the main valve may be done without removing the valve from the water main.

Valve working and surge pressures will be shown on the drawings or designated in the "Special Conditions" of the contract specifications.

D. Check Valves:

Check valves shall be swing type with iron body and flanged ends, meeting all requirements of AWWA C508. Valves to have an iron disc with bronze disc ring and seat ring and lever and weight controlled (American Flow Control Series 2100 in sizes 4" through 12", equivalent).

All internal iron surfaces of the valve shall be coated with a minimum of 8 mils of fusion bonded or liquid epoxy, approved for potable water.

E. Air Relief Valves for Water Lines:

Air relief valves shall be dual operation valves that allow air to escape when the pipeline is being filled and air to enter when the pipeline is being emptied. Valves to be iron with screwed inlet connections and having a 150 psi working pressure (Crispin Universal Air Valves Model No. UL20, with 1/4" orifice, or equivalent).

F. Tapping Sleeve/Saddle and Valve:

*Tapping Sleeves shall be manufactured of ductile iron, cast iron or stainless steel.

*Flanged faced and drilled per ANSI B 16.1, with standard tapping flange counter bore per MSS SP-60. Tapping sleeves shall meet minimum working pressure requirements of 250 psi. Should manufacturer's pressure design standards exceed this requirement, they shall be supplied. All Tapping sleeves shall include a test plug. **When a new water line and the water line being tapped are of the same size, a ductile iron tapping sleeve with mechanical joint must be used.**

Examples of compliant tapping sleeves, on which equivalence will be compared:

<u>Brand/Model</u>	<u>Size Range Approved</u>
Romac SST III with Ductile Iron or Stainless Steel Flange	Approved in sizes 6"x 4" thru 12"x 10"
Mueller H-304 with Ductile Iron or Stainless Steel Flange	Approved in sizes 6"x 4" thru 12"x 10"
*American Flow Control Series 1004	Approved in sizes 6"x 6" thru 20"x 20"
*Mueller H-615	

Note: Tapping sleeves and saddles are to be water pressure tested for leaks, through the test plug, for a period of fifteen (15) minutes at 200 psi or as directed by the Engineer or Inspector. Air testing of the tapping sleeves is not permitted.

*Tapping Saddles shall be ductile iron, flanged faced and drilled per ANSI B 16.1 with standard tapping flange counter bore per MSS SP-60. Straps to be manufactured of alloy steel. Tapping saddles shall meet minimum working pressure requirements of 250psi.

*Tapping Valves shall be mechanical joint x tapping flange. The flanged end shall have a raised face to match counter bore in tapping sleeve outlet per MSS SP-60. Tapping valves shall also conform to the specifications and approved brands as outlined in the valves section.

2.5 FIRE HYDRANTS

*All fire hydrants private and public connected to the City of Conover's water supply shall be Storz dry-barrel fire hydrants, which comply with ANSI/AWWA C502. All hydrants will have a dry top with O-rings seals, which permanently seal off the stem operating threads from water and keep the lubricant in. All hydrants shall be opened by turning counter clockwise, and the direction of the opening shall be indicated by means of an arrow and appropriate wording on the top of the hydrant. The main valve opening shall be 4-1/2" and be a compression type valve. Hydrants must have a bronze main valve seat ring that thread into a bronze drain ring. Each hydrant shall have at least two bronze drain outlets. All hydrants shall have a thrust of anti-friction washer in the operating area of the hydrant bonnet. A weather cap around the operating nut on top of the hydrant is required. All hydrants will have a "6" mechanical joint base connection. Hydrants shall be designed for a minimum working pressure of 250psi. Each hydrant shall be assembled at the factory with one 5" Storz connection and cap. The Storz shall be an intergral in design (no adapters) and meet or exceed AWWA C502, NFPA-1963 and must be UL certified and FM Approved for use on the fire hydrant Each hydrant shall have two 2 1/2" nozzles. All hydrants will be furnished with the breakable traffic feature that will break upon impact. The feature shall consist of a breakaway safety flange shall be 1 to 4 inches above finished grade. All exterior surfaces of hydrants placed in the public right-of-way shall be painted two coats of Safety Yellow" or to the city's satisfaction with Rust-oleum Industrial Enamel Paint 944402 or approved equal. Private fire hydrants shall be painted Red. Hydrant will normally be three and one-half feet from the ground to the bottom of the hydrant. However, when plans indicate deeper bury is required, such hydrants will be furnished conforming to the depth of bury as shown on the plans. A maximum of one (1) barrel extension per hydrant shall be permitted.

2.6 WATER LATERALS AND APPURTENANCES

*This section includes copper water tubing, valves (corporations and curb stops) and meter setting appurtenances, which conform to ANSI/AWWA C800.

*Copper water tubing shall conform to ASTM B-88 (Seamless Copper Water Tubing) standards. Corporations, Curb Stops, and Fittings shall conform to ASTM B-62 and ASTM B-584 UNS NO C83600-85-5-5-5 standards.

A. WATER LATERALS:

*Water Laterals shall be Type K soft copper tubing, conforming to ASTM B-88-62. Couplings for tubing shall have compression connections. (Mueller, A.Y. McDonald, or equivalent). . The longest available length of service line should be used with no unions. As and example for 3/4 inch service connections, no

union shall be used in the installation of 60 feet or less. For 3/4 inch, only one (1) union will be allowed for each one hundred foot section or fraction there of.

B. CORPORATION STOPS

CC thread inlet x compression outlet (3/4" and 1")

2" Ball valve MNPT X FNPT

Examples of compliant corporation stops, on which equivalence will be compared.

	A. Y. McDonald	Mueller
3/4 " Plug Type	4701T	H-15008
1" Plug Type	4701T	H-15008
2" Ball Valve	3149B	B-20046

C. METER SETTERS (Domestic)

*5/8"x 3/4", 3/4" & 1"

Horizontal inlet and outlet meter setters with padlock wing and with ASSE top entry dual check feature. (With compression connections for copper tubing on inlet and double purpose on outlet)

Examples of compliant meter setters, on which equivalence will be compared

	A. Y. McDonald	Mueller
5/8 X 3/4 meter setter	24-207WDTD-33	B-2577-6A
1" meter setter	24-412WDTD-44	B-2577-6A
2" meter setter	20B712WDF775	B-2423-2-01

D. SERVICE SADDLES

*Service saddles shall be double strap design, manufactured of bronze, with corporation thread outlet. The 2" tap service saddles shall have IP thread outlet.

Main Size	Tap Size	A.Y.McDonald	Mueller	Romac	Smith Blair
2"	3/4" – 1"	3891	S-13420		327
3" – 20"	3/4" – 2"		DR2S	202S	317

E. METER BOXES

*For 5/8" x 3/4" And 1" meter installations, the meters box will be manufactured of polypropylene plastic. The cover shall be a drop in reader cover and shall not overlap the top edge of the meter box with a cast iron reader that is stainless steel pinned, (D1500—DICIR manufactured by NDS, or equivalent). A 6" black extension (D750E-EXT) shall be used with the meter box to obtain appropriate bury depth.

For 2" Meters Installations

The dimensions of the meter box shall be 19" wide x 31" long x 18" deep. The meter box and top shall be manufactured of Cast iron (ASTM A 48 Class 30B). (MBX-5A manufactured by Sigma Corporation, or equivalent). **Note: This is a non-traffic rated box.**

3.0 INSTALLATION OF WATER PIPE

A. Description:

*The work covered by this Article consists of furnishing and installing ductile iron water pipe, in an open cut trench, at the locations shown on the drawings. The pipe shall be installed in accordance with all applicable specifications of ANSI/AWWA C600 and the following specifications.

B. Handling and Storage:

*All pipe, fittings, valves, hydrants, and accessories shall be loaded and unloaded by lifting with hoists or skidding in order to avoid shock or damage. Under no circumstances shall the pipe be dropped. Pipe handled on skid ways shall not be rolled or skidded against pipe on the ground.

*Slings, hooks, or pipe tongs shall be padded and used in such a manner as to prevent damage to the exterior surface or interior lining of the pipe.

*Pipe shall not be stacked higher than the limits specified in ANSI/AWWA C600.

*Gaskets for pipe joints shall be stored in a cool location out of direct sunlight. Gaskets shall not come in contact with petroleum products. Gaskets shall be used on a first-in, first-out basis.

C. Alignment and Grade:

The water mains shall be laid and maintained to lines and grades established by the drawings with fittings, valves, and hydrants at the required locations unless otherwise approved by the Engineer. Valve-operating stems shall be oriented in a manner to allow proper operation. Hydrants shall be installed plumb.

When crossing existing pipelines or other structures, alignment and grade shall be adjusted as necessary, with approval of the Engineer, to provide clearance as required by state regulations or as deemed necessary by the Engineer to prevent future damage or contamination of either structure.

D. Pipe Installation:

Proper implements, tools, and facilities shall be provided and used for the safe and convenient performance of the work. All pipe, fittings, valves, and hydrants shall be lowered carefully into the trench by means of a derrick, ropes, or other suitable tools or equipment, in such a manner as to prevent damage to water-main materials and protective coatings and linings. Under no circumstances shall water-main materials be dropped or dumped into the trench. The trench shall be dewatered prior to installation of the pipe.

All pipe fittings, valves, hydrants, and other appurtenances shall be examined carefully for damage and other defects immediately before installation. Defective materials shall be marked and held for inspection by the Engineer, who may prescribe corrective repairs or reject the materials.

All lumps, blisters, and excess coating shall be removed from the socket and plain ends of each pipe, and the outside of the plain end and the inside of the bell shall be wiped clean and dry and be free from dirt, sand, grit, or any foreign material before the pipe is laid.

*Foreign material shall be prevented from entering the pipe while it is being placed in the trench. During laying operations, no debris, tools, clothing, or other materials shall be placed in the pipe. As each length of pipe is placed in the trench, the joint shall be assembled and the pipe brought to correct line and grade. The pipe shall be secured in place with approved backfill material.

*At time when pipe laying is not in progress, the open ends of pipe shall be closed by a watertight plug or other means approved by the Engineer. When practical, the plug shall remain in place until the trench is pumped completely dry. Care must be taken to prevent pipe flotation should the trench fill with water.

*The bell ends of the pipe shall face the direction of laying unless directed otherwise by the Engineer; for lines on an appreciable slope, the Engineer may require that the bell ends face upgrade.

E. Joint Assembly:

*Push-on joints and mechanical joints shall be assembled as outlined under 4.3.4.1 and 4.3.4.2 of the ANSI/AWWA C600 Specifications.

*When it is necessary to deflect pipe from a straight line in either the vertical or horizontal plane, or where long radius curves are permitted, the amount of deflection shall not exceed that shown below. In no event shall more deflection be allowed than the manufacturer's recommended maximum. The maximum deflection shown is for a 20-ft. length of pipe with push-on joints. The pipe sizes and maximum deflections are shown in inches.

<u>Pipe Size</u>	<u>Maximum Deflection</u>
4" thru 12"	21°
14" thru 36"	12°

*Cutting pipe for the insertion of valves, fittings, or closure pieces shall be done in a neat, workman like manner without creating damage to the pipe or cement-mortar lining. Pipe may be cut using an abrasive pipe saw, rotary wheel cutter, guillotine pipe saw, milling wheel saw. Cut ends and rough edges shall be ground smooth, and for push-on joint connections, the end shall be beveled.

3.1 VALVE AND FITTING INSTALLATION

A. Description:

*The work covered by this Article consists of furnishing and installing valves and pipe fittings, in an open cut trench, at the locations shown on the drawings.

B. Construction Requirements:

*All valves 20-inches and smaller shall be resilient seat/wedge gate valves. Valves shall conform to Sub-Article 2.5A, 2.5B, or 2.5C. of these specifications.

*Prior to installation, valves shall be inspected for direction of opening, freedom of operation, tightness of pressure-containing bolting, cleanliness of valve ports and especially seating surfaces, handling damage, and cracks. Defective valves shall be corrected or held for inspection by the Engineer.

*Valves, fittings, plugs, and caps shall be set and joined to the pipe in the manner specified in Sub-Articles 3.0D. and 3.0E. for cleaning, laying, and joining pipe, except that valves 16- inches and larger shall be provided with special support, such as crushed stone, concrete or masonry pads, or sufficiently tamped trench bottom so that the pipe will not be required to support the weight of the valve. Fittings shall be ductile iron as specified in Section 2 of these specifications.

*Unless designated otherwise on the drawings or in the Special Conditions, a valve box with necessary extension shall be provided for every valve. The valve box shall not transmit shock or stress to the valve and shall be centered over the operating nut with the use of a 6" double-hub coupling or the bell of the cast iron stack piece. The box cover shall be installed flush with the surface of the finished area, or as may be directed by the Engineer.

*In no case shall valves be used to bring misaligned pipe into alignment during installation. Pipe shall be supported in such a manner as to prevent stress on the valve.

*All dead ends on new mains shall be closed with plugs or caps that are suitably restrained to prevent blowing off under test pressure. If a blow-off valve precedes the plug or cap, it too shall be restrained against blowing off. All dead ends shall be equipped with suitable blow-off facilities. Blow-off facilities for main sizes 2-inch thru 8-inch shall conform to the City of Conover Standard Detail Drawing No. 7.3W.

*For main sizes larger than 8-inch, fire hydrants or blow-off assemblies, 4 inch and larger, shall be installed in accordance with approved construction drawings.

*Blow offs and associated drainage lines shall not be connected to any type sewer or submerged in any stream or installed in any manner that would permit back siphonage into the City's water distribution system. Blow-offs 4-inch and larger shall require a flap valve to be installed at the end of the drainage line.

*All plugs, caps, tees, and bends, unless otherwise specified, shall be provided with concrete reaction blocking, Meg-A-Lug type restraint systems (see 2.06 mechanical joint restraints) or suitably restrained joints as indicated on the drawings or directed by the Engineer. Concrete reaction blocking shall be placed between solid ground and the fitting to be anchored; the area of bearing on the pipe and on the ground in each instance shall be that shown on the drawings or directed by the Engineer. The blocking shall, unless otherwise shown or directed, be so located as to contain the resultant thrust force and so that the pipe and fitting joints will be accessible for repair. Where concrete must be reinforced, the Contractor shall furnish such reinforcing as is required. No direct payment will be made for concrete reaction blocking and reinforcement for pipe sizes up to and including 16-inches in diameter. A bid item for concrete reaction blocking will be listed in the Itemized Proposal for pipe sizes over 16-inches in diameter.

*All hydrant valves shall be restrained to the main line with a Swivel Hydrant Tee and rotating split gland. All branch line valves shall be restrained to the main line where a valve may blow off during testing or where future extension of the branch line is possible. The branch line valve shall be restrained with restraint devices other than concrete blocking.

3.2 TAPPING SLEEVE AND VALVE INSTALLATION

A. Description:

*The work covered by this Article consists of excavating an area of sufficient size to tap an existing water line and set a valve, furnishing and installing a tapping sleeve and valve, performing the water line tap, and backfilling and compacting the area. The locations and sizes will be designated on the drawings or directed by the Engineer.

B. Construction Requirements:

*The Contractor shall furnish and install the tapping sleeve and valve conforming to Section 2.5 (F). The Contractor will do the tapping of the existing main according to manufacturer's specifications.

*The Contractor shall excavate an area of sufficient size and depth, conforming to OSHA requirements, to accommodate the operations of tapping the existing line and setting the valve.

*The Contractor shall furnish and install a valve box with the necessary extensions, backfill and compact the excavated area. The backfill material and compaction shall meet all applicable requirements of Sub-Article 1.4 (B).

*The Contractor shall perform a 200 psi pressure test, or a different pressure as required by the Engineer, on the tapping sleeve and valve prior to tapping the existing water main. This pressure test will be performed using the test plug provided with the tapping sleeve.

***Air testing of the tapping sleeves is not permitted.**

3.3 HYDRANT INSTALLATION

A. General:

*The work covered by this article consists of furnishing and installing fire hydrants, in an open cut trench, at the locations shown on the drawings.

*All fire hydrant connections shall be made on the water main by using a **mechanical joint tee with the restrained swivel branch outlet**. This provides a restrained connection between the tee and the mechanical joint valve. The hydrant lead is typically made of the same material as the main. That is, if the main is made of ductile iron, then the hydrant lead is made of ductile iron. If the main is PVC, then the hydrant lead should be made of PVC.

*Beyond the valve, the hydrant can be installed by one of the following methods.

1. Connect the fire hydrant to the outlet side of the mechanical joint valve with a mechanical joint swivel by mechanical joint solid adapter. This method provides positive restraint when short distances between the valve and the hydrant are required.

2. When the water main is ductile iron the contractor may connect the fire hydrant to the outlet side of the mechanical joint valve with a proper length of ductile iron pipe, using wedge type mechanical joint retainer glands on the connections between the valve and the hydrant.

3. When the water main is PVC the Contractor shall connect the fire hydrant to the outlet side of the mechanical joint valve with a proper length of PVC pipe. Using two (2) $\frac{3}{4}$ all thread rods the connections between the valve and the hydrant shall be rodded.

4. The bowl or elbow of each hydrant shall be well braced against a sufficient area of unexcavated earth at the end of the trench with a solid and sound 4"x 8"x 16" cap block. The area of bearing on the hydrant and on the unexcavated earth in each instance shall be that shown on the drawings, or as directed by the Engineer.

B. Construction Requirements:

*Prior to installation, inspect all hydrants for direction of opening, nozzle threading, operating nut and cap-nut dimensions, tightness of pressure-containing bolting, cleanliness of inlet elbow, handling damage, and cracks. Defective hydrants shall be corrected or held for inspection by the Engineer

*Any dirt or foreign matter shall be removed from all hydrants before they are set.

Hydrants set in soil that is impervious shall have a drainage pit two feet in diameter and two feet deep excavated below the bowl. This pit shall be filled with either No. 57 or 67 stone to a point six inches above the drain port. Hydrants set in soil that is pervious shall have either No. 57 or 67 stone placed around the bowl to a point 12 inches above the drain port and a minimum of 12 inches laterally in all directions.

*All hydrants shall be set plumb and shall have their nozzles parallel with the existing or future curb, with the pumper nozzle facing the curb.

*At the locations designated on the drawings, or where directed by the Engineer, the Contractor shall furnish hydrants with a barrel that will allow a bury depth greater than the standard three and one-half foot bury hydrant. A maximum of one (1) barrel extension per hydrant shall be permitted.

3.4 BLOW-OFFS

A. Description:

*The work covered by this Article consists of furnishing and installing water main blow-offs for main sizes 2-inches thru 8-inches. Blow-offs for main sizes over 8-inches and blow-offs that have special requirements will be covered in the Special Conditions.

B. Construction Requirements:

*All dead ends on new mains shall be closed with plugs or caps that are suitably restrained to prevent blowing off under test pressure. If a blow-off valve precedes the plug or cap, it too shall be restrained against blowing off. All dead ends shall be equipped with suitable blow-off facilities per the City of Conover Standard Detail Drawing No.7.3W.

Blow-offs and associated drainage lines shall not be connected to any type sewer or submerged in any stream or installed in any manner that would permit back siphonage into the City's water distribution system. Blow-offs 4-inch and larger shall require a flap valve to be installed at the end of the drainage line.

*The Contractor shall provide a tap with a prethreaded plug or cap at the end of the water main; furnish and install a threaded connection; trench and backfill for the blow-off line;

*The size of blow-offs on water mains shall be as follows:

<u>Main Size</u>	<u>Blow-off Size</u>
2"	2"
4"	2"
6"	2" or Hyd.
8"	2" or Hyd.
10"	4" or Hyd.
12"	4" or Hyd.
16"	4" or Hyd.
20"	6" or Hyd.

3.5 WATER SERVICE LATERALS

A. Description:

*The work covered by this Article consists of furnishing and installing water service laterals in an open cut trench or in unlined bores.

B. Construction Requirements:

*Water service laterals shall be installed in accordance with the City of Conover Standard Detail Drawing No. 1W

*The water main shall be thoroughly flushed, using a flow velocity sufficient to scour the pipe interior, before any water laterals are installed.

*The Contractor shall trench and backfill or bore for the water lateral; tap the water main; furnish and install a corporation stop, the necessary copper tubing, a meter setter, and a meter box.

*The threaded portion of the corporation stop shall be wrapped with pipe dope before the stop is installed in the tapping saddle. Each meter setter shall be flushed briefly immediately after it has been installed. The trench and backfill operations shall be performed in accordance with all applicable provisions of Sub-Article 1.4.

*Bores shall be of adequate size to accommodate the lateral without causing an excessive void around the pipe. The face of the bore shall be a distance of five feet from the edge of pavement or back of curb on either side of the roadway unless approval to the contrary is given by the Engineer.

*Taps shall only be made after the water main is under pressure. No taps on dry mains will be allowed unless specific authorization is obtained from the Engineer. Taps shall be on an angle 45 degrees to a perpendicular through the centerline of the pipe.

3.6 PRESSURE TESTING AND DISINFECTION OF WATER LINES

A. Pressure Testing:

*The Contractor shall furnish all labor and equipment necessary to perform the pressure tests. The pressure test shall be performed by the Contractor and observed by the Inspector and/or Engineer. Testing procedures should be conducted in accordance to AWWA standards C600 and C605. Existing valves may not be used for testing.

*Unless modified in the project special provisions, the test pressure shall be 200 psi as measured at the lowest elevation of the line. The duration of the test shall be two hours. The 200 psi test pressure shall be maintained during the two hours by use of a by-pass pumping system.

*Allowable leakage per 1,000 linear feet of pipe per two hours shall be as follows:

Note: If pressure testing of the water line fails due to one or more leaking joints, those joints shall be cut out or removed from the pipe installation and closure shall be made with suitable lengths of pipe and mechanical joint solid sleeves. **Bell joint repair clamps are not permitted.**

Pipe Size (Inches)	Allowable Leakage (Gallons)
4	0.73
6	1.11
8	1.47
10	1.84
12	2.21
14	2.57
16	2.94
20	3.68

*The following prerequisite conditions shall have been met before any pressure testing begins:

- (1) All hydrants are properly located, operable, plumb, and at correct elevation.
- (2) All valves are properly located, operable, and at correct elevation, with valve boxes or manholes centered over wrench nuts, and top of box or manhole at correct elevation.
- (3) The water line or lines are properly vented where entrapped air is a consideration.

B. Disinfection of Mains:

*All water lines or appurtenances added to or replaced in the City of Conover water system shall be properly chlorinated before being placed in service. The Contractor under the supervision of the Engineer or Conover Inspector shall perform the chlorination.

1. All of the water mains installed shall be thoroughly flushed and disinfected before being placed in service. This work shall be done under the direct supervision of the Engineer's Inspector and shall follow ANSI/AWWA C651 and NC Administrative Code. The AWWA continuous feed method shall be used, unless otherwise approved by the engineer. The specifications below are based on the continuous feed method and as modified to Conover Water Standards. The Contractor shall supply all labor, equipment and materials necessary for carrying out this work.

2. Filling and Flushing for Disinfection and Sampling: All water usage shall be measured by the water meter required in the jumper assembly. Meter readings shall be documented and recorded daily. The document shall indicate the reason for the water usage each day. The readings shall be provided to the Engineer prior to removal of the jumper/meter assembly. All water usage shall pass through the approved reduced pressure backflow assemblies. Conover Water shall provide water free of charge to the Contractor for the chlorination, flushing and sampling processes one time or a total of 3 pipe water volumes. All additional water required for additional disinfection, flushing, and sampling shall be billed to the Contractor at the bulk water billing rate.
3. Flushing and cleaning are done prior to the pressure test. Sufficient hypochlorite or other chlorine compounds shall be introduced in the lines to produce a chlorine concentration of at least 50 parts per million and not greater than 150 parts per million. Where a direct connection to active water main is required, jumper assembly shall be used for the connection. The jumper shall be inspected by a representative of the Owner and tested by a third-party certified backflow tester prior to use. The jumper shall be located no greater than 10 feet from the chlorination injection point.
4. The chlorine solution shall be retained in the lines for at least twenty-four (24) hours and no greater than 36 hours and tracked at each blow off sampling location. Sampling locations are required every 1200 feet of water main line and at any dead-end line. Blow off standpipes used for sample points shall be a minimum of 24-inches tall and include an extension at a 45- or 90-degree angle of at least 18 inches in length. The blow off shall be constructed of rigid metal pipe and shall end without threads. Fire hydrants are not to be used as sampling points but shall be chlorinated and flushed after 24 hours. At the end of the 24-hour chlorination period, the chlorine residual shall be at least 10 parts per million, prior to flushing. The inspector shall witness the chlorine residual tests at each blow off and sampling location and record the results before the Contractor is approved to begin the flushing and dichlorination processes.
5. The water mains shall then be flushed sufficiently to clear them of chlorine exceeding 0.80 ppm. Chlorine testing shall be witnessed/verified by the Conover Water inspector. The flushing velocity shall be no less than 3.0 ft/s. All water services, regardless of size or type, shall be flushed to remove high chlorine concentrations once the water main has been flushed and tested to below 0.80 PPM. This flushing shall be completed within 48-hours of the disinfection processes.

C. Bacteriological Sampling:

1. The Contractor shall collect samples of water from the mains shall then be taken and analyzed for bacteriological purity. Water shall be running at a low flow rate for a minimum of 2 hours prior to the sample collection. A representative of the Owner shall be present at the time of sample collection. Samples shall be analyzed by a Certified Laboratory. Results typically take 24 hours and only the Owner may call the laboratory if there are questions regarding the testing. If one sample from the mains fail to meet the bacteriological standard for purity, additional samples shall be collected and retested.

2. If the samples fail three times, disinfecting and flushing shall be repeated until such standards have been met. The Contractor is responsible for the cost of the water required for the additional flushing, disinfection and sampling.

At the satisfactory completion of the bacteriological requirements, the lines shall be placed into service under the supervision of the Water Dept. personnel.

4.0 BACKFLOW PROTECTION

A. General:

Backflow protection devices shall be installed, tested, and maintained by the customer. Such devices shall be required on all plumbing connections to service lines for irrigation, and to all premises except service to single-family residential dwellings. Such devices shall be installed on the customer's plumbing line beyond the water meter but prior to any branching of plumbing lines from the common line, such that all water passing through the water meter shall also pass through the protection device. No water shall be permitted at any time to by-pass backflow protection; if the customer requires a by-pass while the backflow device is being tested or repaired, the by-pass line shall include a backflow device of equal design and size as the first.

B. Type of Device Required:

The type of backflow device required shall be based on a determination of the potential degree of hazard of backflow at the facility receiving water service. Hazards shall be classified as high or moderate as referenced in the City of Conover Cross Connection Control Ordinance. Acceptable backflow devices for each degree of hazard are defined below:

1. High Hazard:

Reduced Pressure Zone Backflow Assembly
Atmospheric air Gap of Length a Least two (2) Times Inlet Pipe Inside Diameter

2. Moderate Hazard:

Double Check Valve Assembly

AVERAGE DAILY WATER DEMANDS

TYPE	ESTIMATED WATER USAGE
Residential	400 gpd per house
Multi dwelling residential	One Bedroom – 200 gpd per unit Two Bedroom – 300 gpd per unit Three Bedroom – 400 gpd per unit
Mobile Homes	250 gpd per unit
Bowling Alley	100 gpd per lane
Barber Shop	100 gpd per chair
Beauty Shop	125 gpd per chair
Dentist Office	750 gpd per chair
Drug Store	500 gpd
With Fountain Service	add 1,200 to 1,500 gpd
Serving Meals	add 50 gpd per seat
Industrial Plant	30 gpd per employee
Launderette	1,000 gpd per unit
Meat Market	5 gpd per 100 sq. ft. floor area
Motel or Hotel	125 gpd per room
Office Building	12 gpd per 100 sq. ft. floor area
Physician's Office	200 gpd per examining room
Retirement Home/Nursing Home	100 gpd per patient/employee
Restaurant	20-50-120 gpd per seat
Restaurant (drive-in)	20 gpd per car space
Service Station	1,000 gpd per pump island
Theater	3 gpd per seat
Theater (drive in)	3 gpd per car space
*Not including process water	
Boarding School, elementary	75 pgd per person
Boarding Schools, Senior	100 gpd per person
Churches	3 gpd per person
Clubs, County	25 gpd per person
Clubs, Civic	3 gpd per person
College, Day Students	25 gpd per person
College, Junior	100 gpd per person
College, Senior	100 gpd per person
Elementary Schools	16 gpd per person
Junior High Schools	25 gpd per person
Nursing Homes	100 gpd per person
Prisons	60 gpd per person
Rooming Houses	100 gpd per person
Summer Camps	60 gpd per person

SIZING WATER SERVICE LINES AND METERS

Plumbing Fixture Value

Fixture Type	Fixture Value Based on 35 psi At Meter Outlet
Bathtub.....	8
Bedpan washers.....	10
Combination sink and tray.....	3
Dental unit.....	1
Dental lavatory.....	2
Drinking fountain (cooler).....	1
Drinking fountain (public).....	2
Kitchen sink:	
1/2-inch connection.....	3
3/4-inch connection.....	7
Lavatory	
3/8 inch connection.....	2
1/2 inch connection.....	4
Laundry try	
1/2 inch.....	3
3/4 inch.....	7
Shower head (shower only).....	4
Service sink:	
1/2-inch connection.....	3
3/4-inch connection.....	7
Urinal:	
Pedestal flush valve.....	35
Wall or stall.....	12
Through (2 ft. unit).....	2
Wash sink (each set of faucets)....	4
Water closet:	
flush valve.....	35
Tank type.....	3
Dishwasher:	
1/2 inch connection.....	4
3/4 inch.....	12
1 inch connection.....	25
Hose connections (wash down:)	
1/2 inch.....	6
3/4 inch.....	10
Hose (50 ft. length wash down:)	
1/2 inch.....	6
5/8 inch.....	9
3/4 inch.....	12

SIZING WATER SERVICE LINES AND METERS

Customer: _____ **Address:** _____
Building Address: _____ **Zip Code:** _____
Sub-division: _____ **Lot No.:** _____ **Blk. No. :** _____
Type of Company: _____

Fixture		Fixture Value 35psi	No. of Fixtures	Fixture Value
Bathtub		x	=	
Bedpan		x	=	
Washers		x	=	
Combination Sink and Tray		x	=	
Dental Lavatory		x	=	
Drinking Fountain:	Cooler	x	=	
	Public	x	=	
Kitchen Sink:	1/2" connection	x	=	
	3/4" connection	x	=	
Shower Head (shower only)		x	=	
Service Sink:	1/2" connection	x	=	
	3/4" connection	x	=	
Urinal:	Pedestal flush valve	x	=	
	Wall flush valve	x	=	
	Trough (2 ft. unit)	x	=	
Wash Sink (each set of faucets)		x	=	
Water Closet:	Flush valve	x	=	
	Tank type	x	=	
Dishwasher:	1/2" connection	x	=	
	3/4" connection	x	=	
Washing Machine:	1/2" connection	x	=	
	3/4" connection	x	=	
	1" connection	x	=	
Hose Connection (wash down):	1/2" connection	x	=	
	3/4" connection	x	=	
Hose (50 ft. wash down):	1/2" connection	x	=	
	5/8" connection	x	=	
	3/4" connection	x	=	

Combined Fixture Value Total	=	Gpm.
Customer Peak Demand from fig. 4.04 or 4.05 x Press Factor	=	Gpm.
Add irrigation: - _____ Squares x 1.16 or 0.40 ⁽¹⁾	=	Gpm.
Add fixed load: - _____ Hose Bibs x 6.5x _____ Press Factor	=	Gpm.
Total Fixed Demand	=	Gpm.

SIZING WATER SERVICE LINES AND METERS

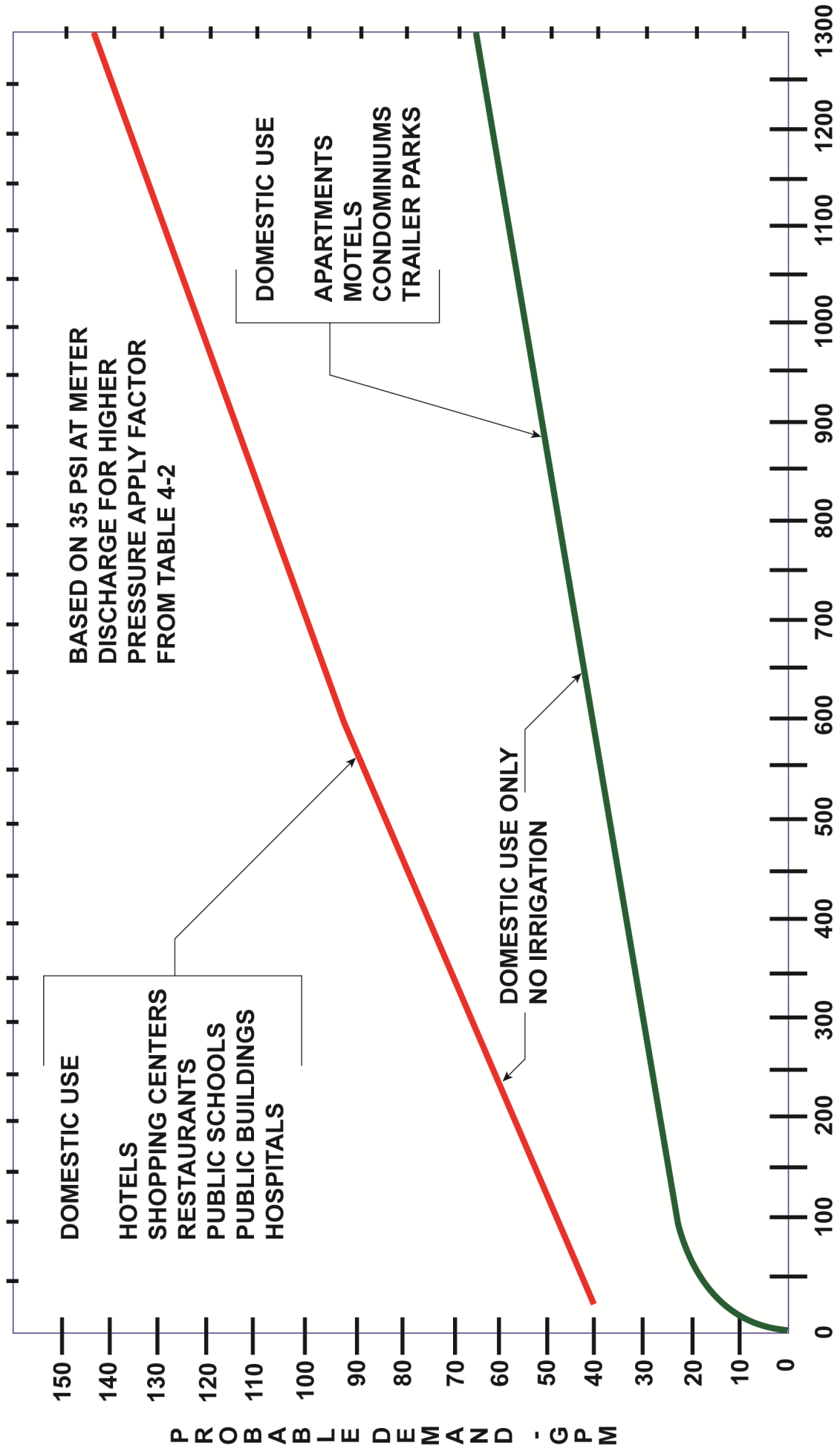

FIG. 4.4 WATER-FLOW DEMAND PER FIXTURE VALUE - LOW RANGE

SIZING WATER SERVICE LINES AND METERS

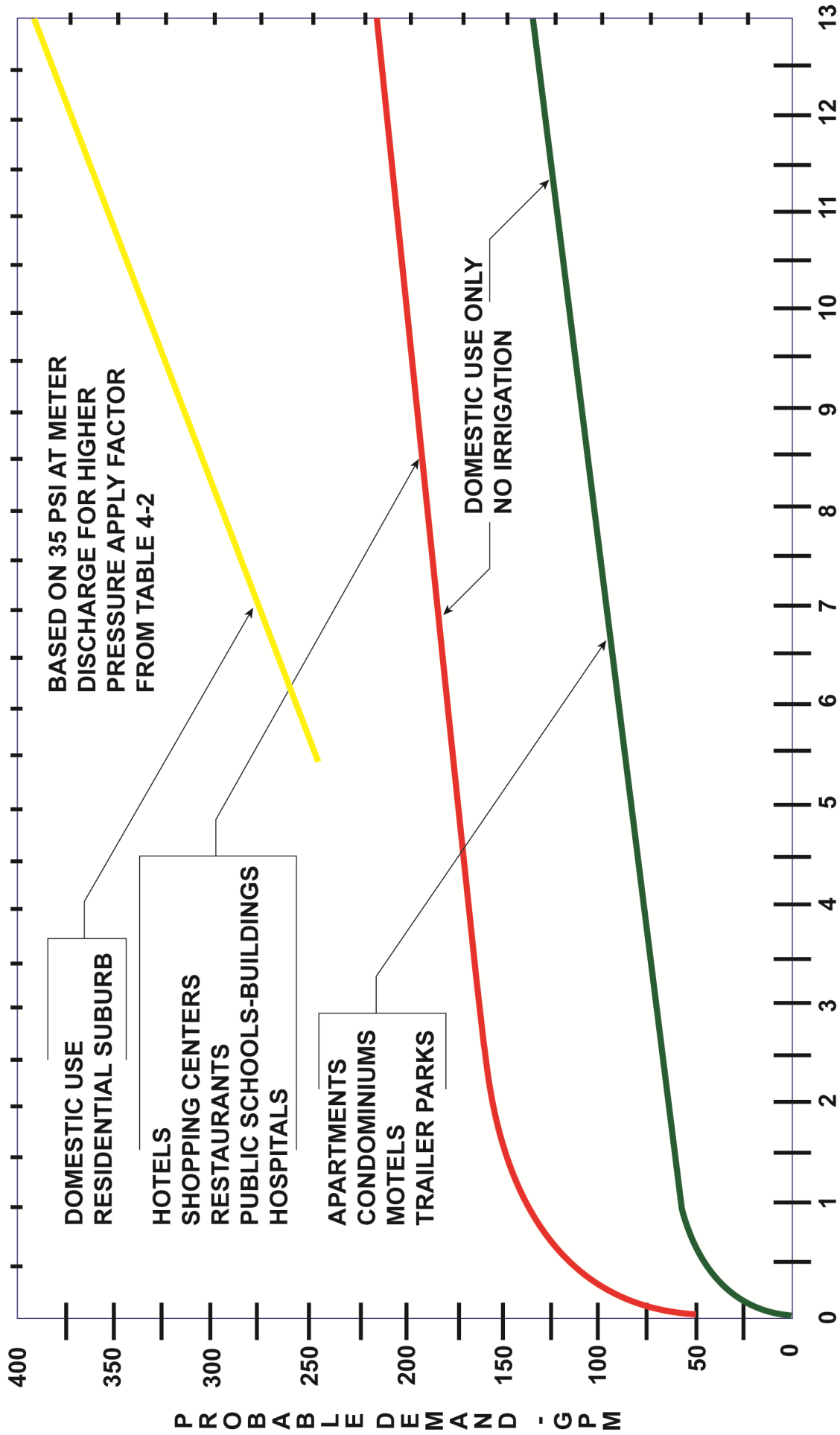

FIG. 4.4 WATER-FLOW DEMAND PER FIXTURE VALUE - LOW RANGE

ENGINEER'S CERTIFICATE OF COMPLETION

water

TO:

FROM:

DATE:

RE: Certification of Completion

Name of Development: _____

Project No. _____

I, the undersigned, hereby certify:

1. That the water improvements to the above referenced development have been installed as shown on the attached "as-built" reproducible drawing.
2. That the water improvements to the above referenced development have been installed in accordance with the specifications and requirements of the City of Conover Standard Specifications and Details.
3. That all necessary easements for the water improvements have been recorded in the Catawba County Register of Deeds and are shown on the attached plot and deed easement.
4. That the water improvements have been installed in accordance with the "Potable Water Distribution Data Sheet".

SIGNATURE OF PROFESSIONAL ENGINEER

DATE

FIRM

LICENSE NO.

CONTRACTOR'S CERTIFICATE OF COMPLETION

water

TO:

FROM:

DATE:

Certification of Completion

RE: Name of Development: _____

Project No. _____

I, the undersigned, hereby certify:

1. We are Licensed Utility Contractors in the State of North Carolina.
2. That the water improvements to the above referenced development have been installed in accordance with the specifications and requirements of the City of Conover.
3. That we guarantee the materials and installation of the water lines including all appurtenances and the restoration of any disturbed areas for a period of one (1) year and shall make repairs deemed necessary by the City of Conover. The one-year period shall begin on the date the City of Conover Council accepts the project.
4. That we will reimburse the City of Conover the cost of any repairs it deems necessary to make its own forces including the cost of materials, labor, and equipment if we can not make the repair at the time it is needed.

NAME

DATE

CORPORATION / COMPANY

LICENSE NO.

ENGINEERING DEPARTMENT SUBMITTAL POTABLE WATER DISTRIBUTION DATA SHEETS

1. Provisions must be made with respect to line sizing and easements to adjoining undeveloped properties and previously developed properties.

2. Water Distribution System Checklist:

The proposed water system extension is to be dedicated to the City of Conover.

Maximum hydrant spacing does not exceed 1,000 linear feet.

Maximum in-line valve spacing does not exceed 1,500 linear feet.

Three (3) valves are provided at each tee.

Four (4) valves are provided at each cross.

All lines meet State requirements with respect to size, area served and loops.

All lines are to be looped where possible.

All crossings with sewer lines meet State requirements of separation and materials.

All utilities (existing and proposed) are separated by ten feet in existing public rights-of-way or 25' permanent utility easement.

Fire hydrants, flushing hydrants or blow-offs are provided at all dead-end mains.

All tees, bends and fire hydrants have been provided with thrust blocks, tie rods as required.

Twenty-five (25') permanent utility easements, centered on extensions, shall be dedicated to the City of Conover or is located within the right-of-way of a publicly maintained highway.

<input type="checkbox"/>
<input type="checkbox"/>
<input type="checkbox"/>
<input type="checkbox"/>
<input type="checkbox"/>
<input type="checkbox"/>
<input type="checkbox"/>
<input type="checkbox"/>
<input type="checkbox"/>
<input type="checkbox"/>
<input type="checkbox"/>
<input type="checkbox"/>

3. The City of Conover may require hydraulics ran if an area is in question. Attach a sketch map of the proposed water distribution system indicating the point location used for your hydraulic calculations as shown in the following table.

4. The design engineer, licensed in North Carolina, shall inspect the construction, furnish as-built drawings to the City of Conover along with a certification that the extension was built in strict accordance with the City of Conover's Specification and requirements.

Seal and Signature

Date

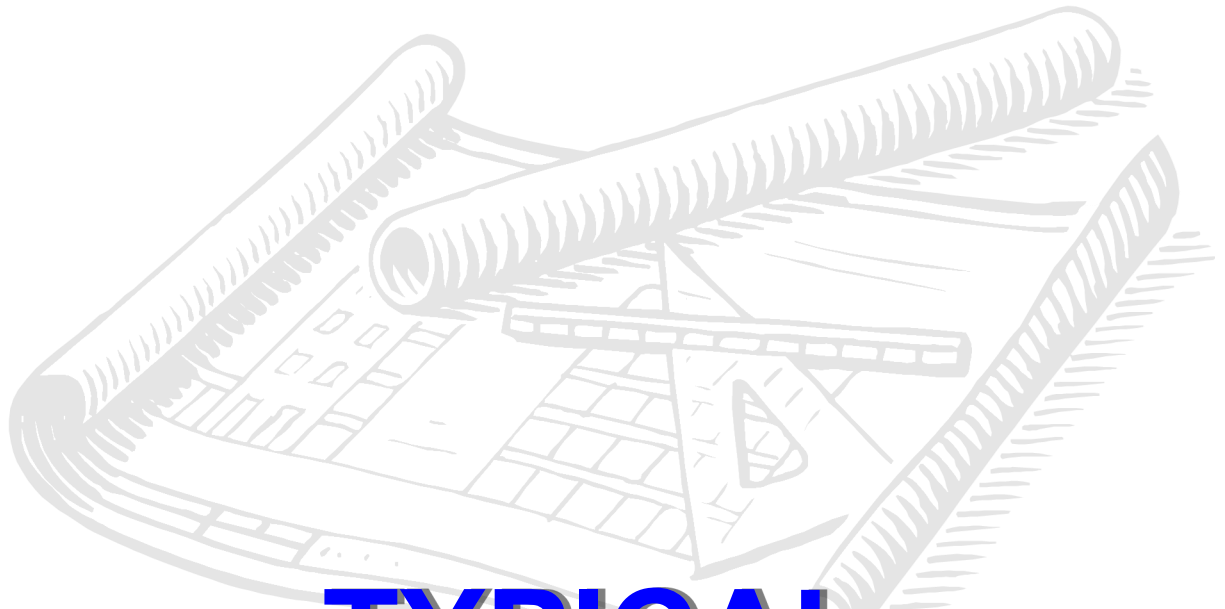

TYPICAL DESIGN DETAILS

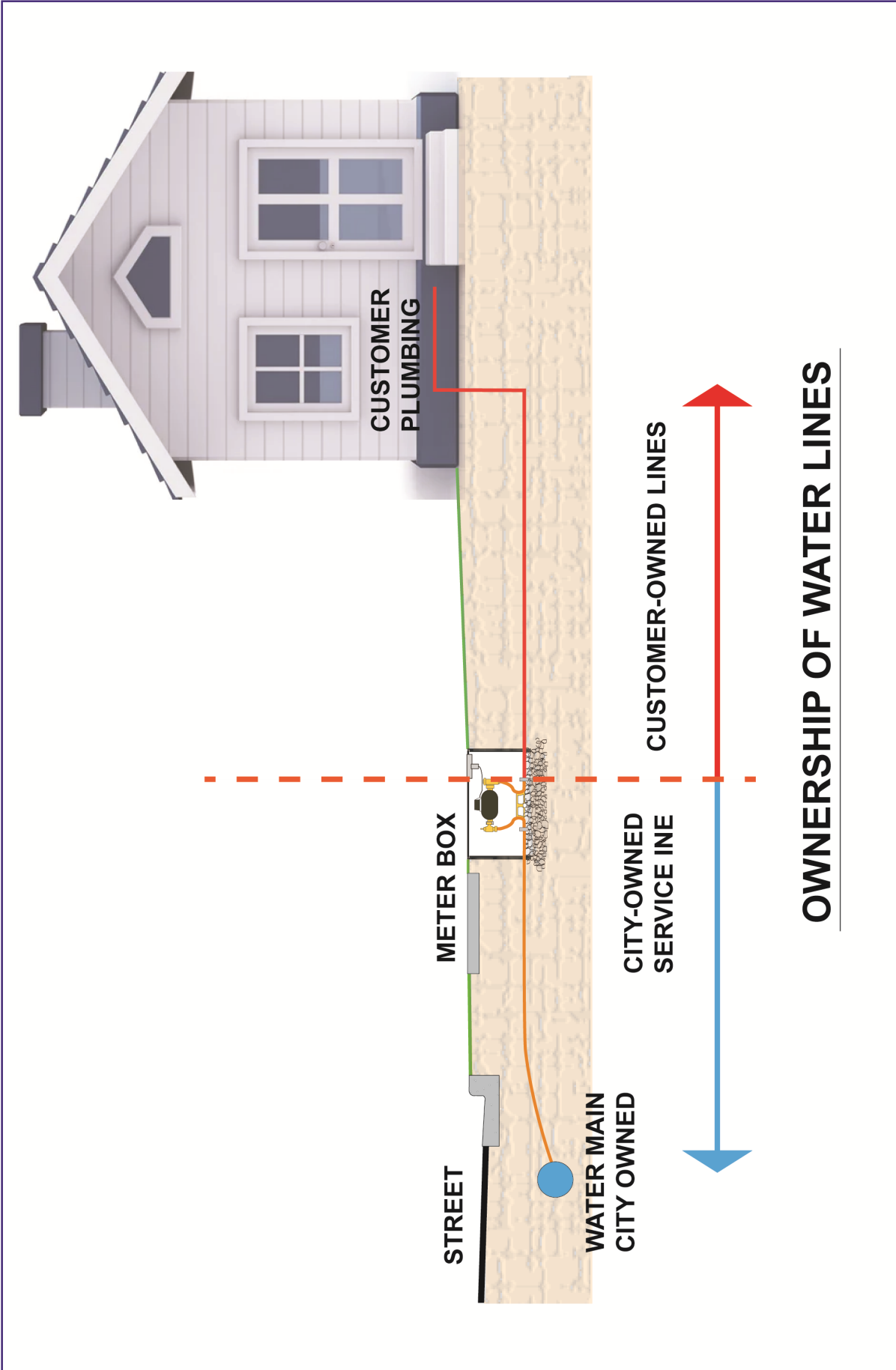

OWNERSHIP OF WATER LINES



CITY OF CONOVER
PUBLIC UTILITIES DEPARTMENT

OWNERSHIP OF WATER LINES

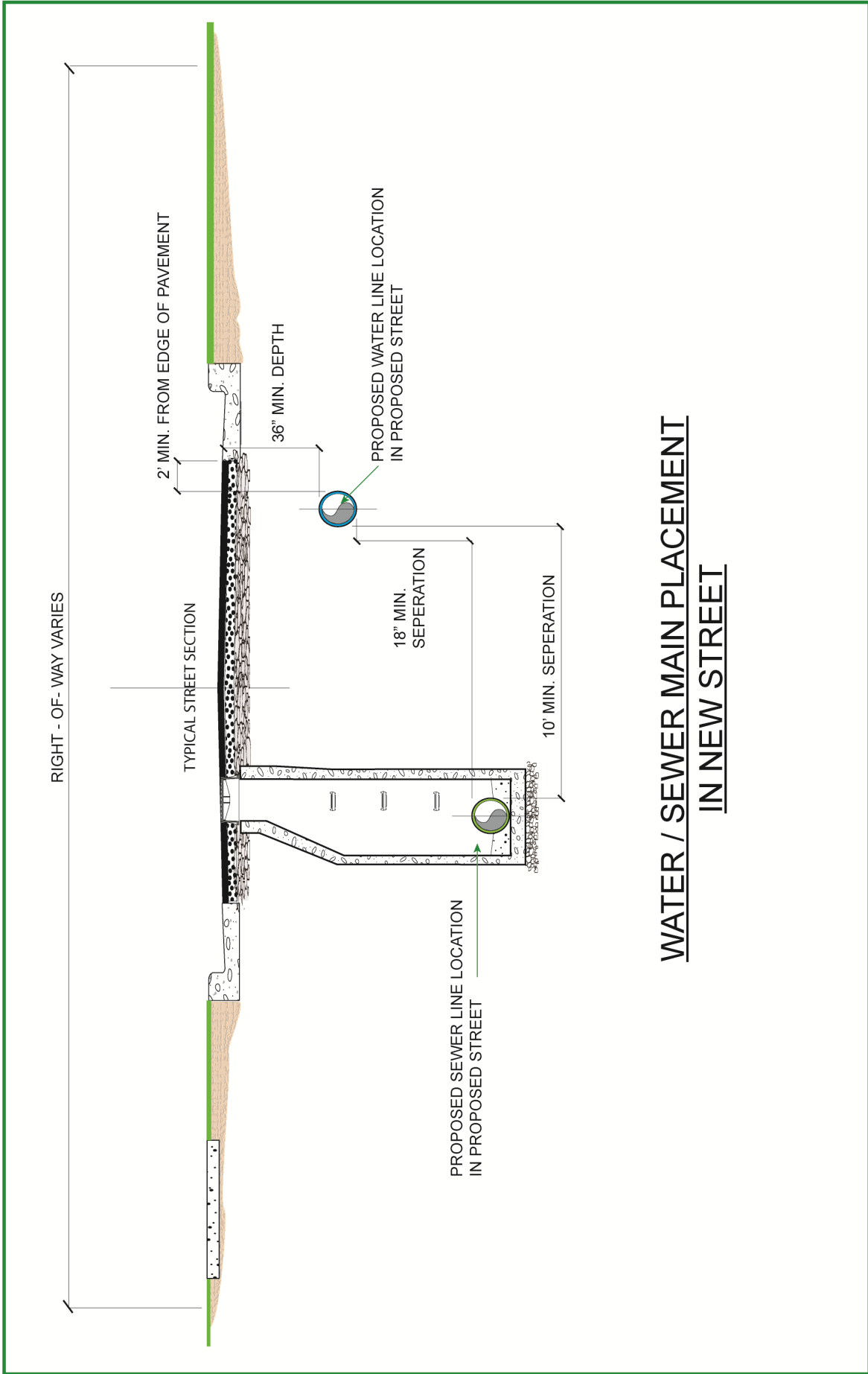

**WATER / SEWER MAIN PLACEMENT
IN NEW STREET**



**STANDARD PLACEMENT OF UTILITIES
CITY OF CONOVER
PUBLIC UTILITIES DEPARTMENT**

**TYPICAL DESIGN STANDARDS
PLACEMENT OF WATER / SEWER MAIN
IN STREET SECTION**

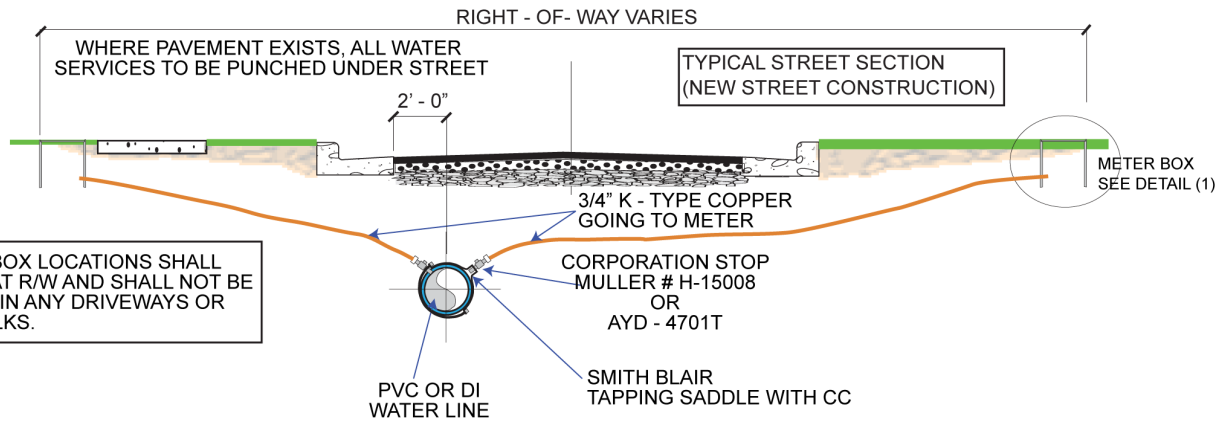

PROFILE

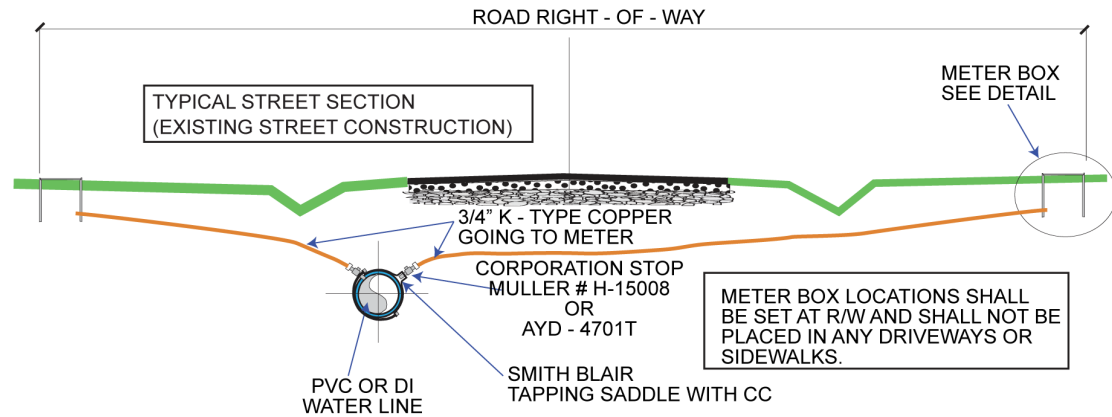

PROFILE

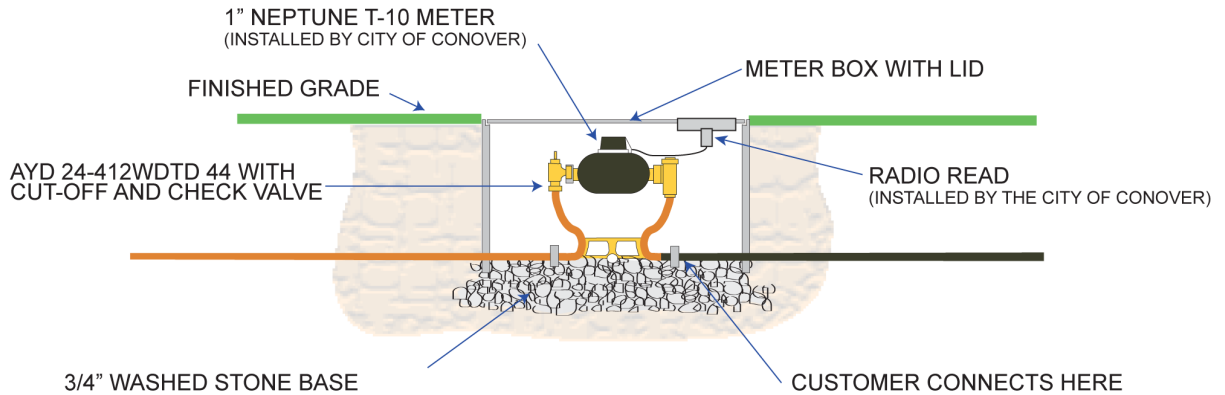

DETAIL " 1 "

TYPICAL 3/4" WATER SERVICE CONNECTION TO PVC or DI WATER LINE W/ SETTER



STANDARD # 100W

CITY OF CONOVER
PUBLIC UTILITIES DEPARTMENT

TYPICAL DESIGN STANDARDS
3/4" WATER SERVICE CONNECTION
TO PVC or DI WATER LINE

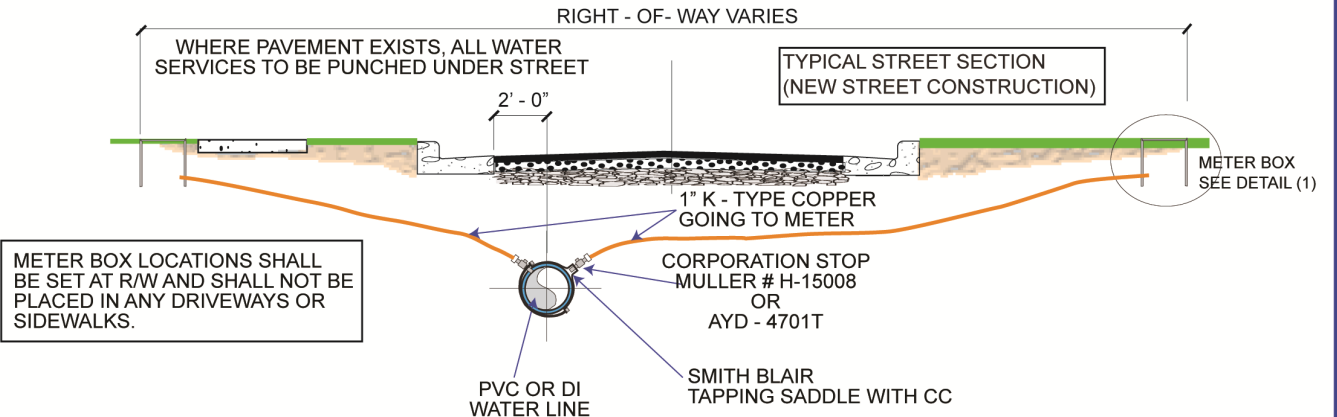

PROFILE

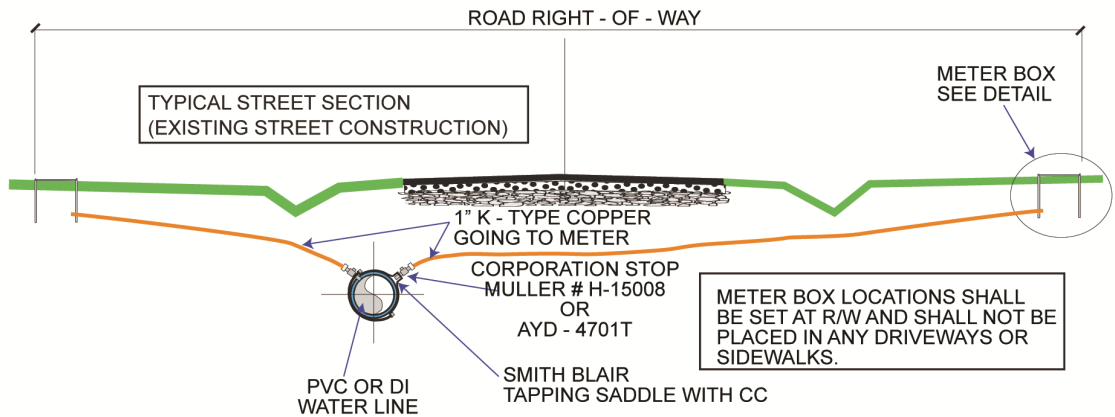

PROFILE

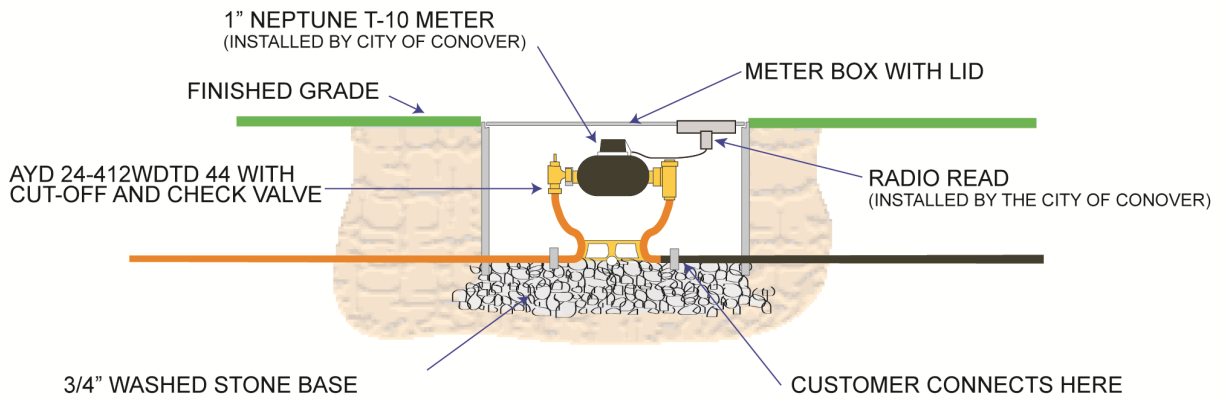

DETAIL " 1 "

TYPICAL 1" WATER SERVICE CONNECTION TO PVC or DI WATER LINE W/ SETTER



STANDARD # 101W

CITY OF CONOVER
PUBLIC UTILITIES DEPARTMENT

TYPICAL DESIGN STANDARDS
1" WATER SERVICE CONNECTION
TO PVC or DI WATER LINE

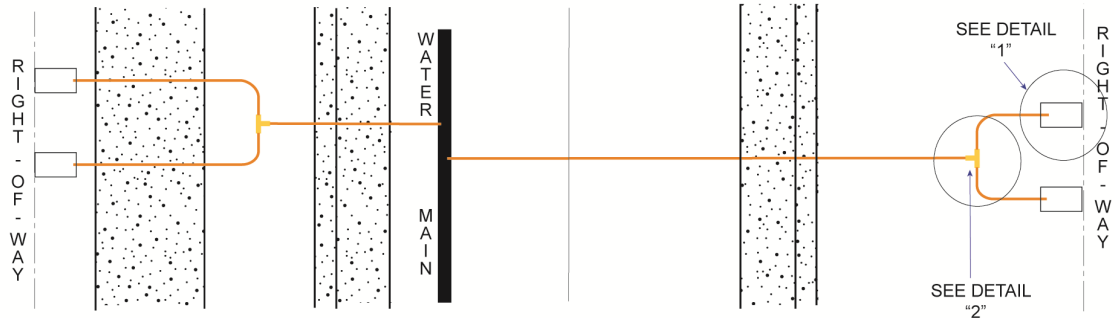

PLAN

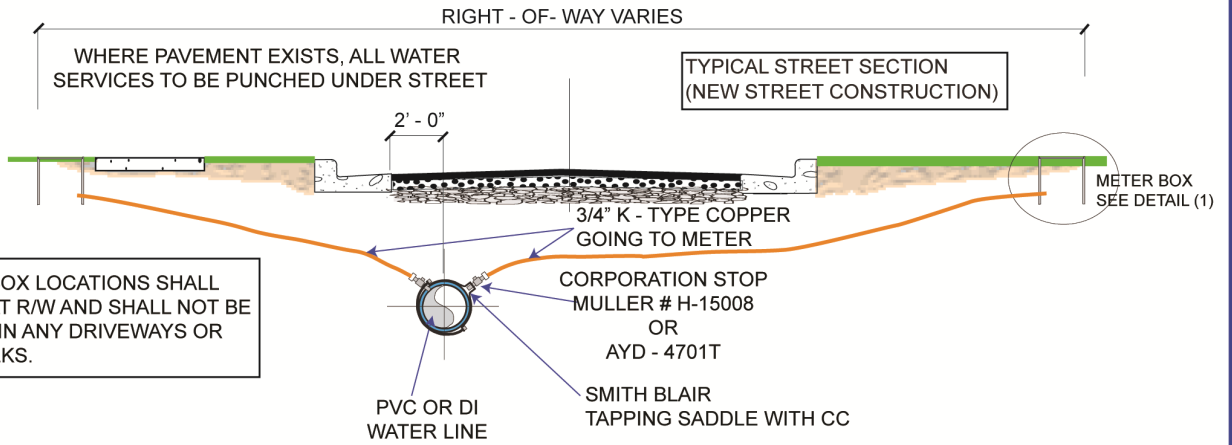

METER BOX LOCATIONS SHALL BE SET AT R/W AND SHALL NOT BE PLACED IN ANY DRIVEWAYS OR SIDEWALKS.

PROFILE

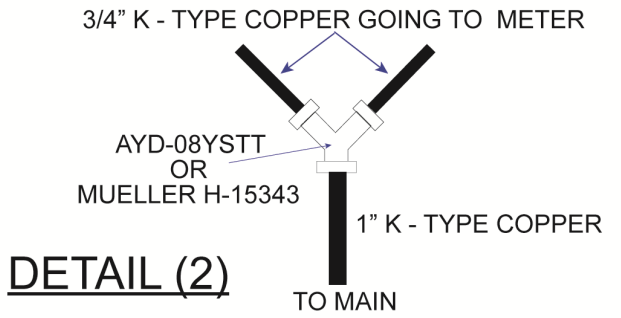

DETAIL (2)

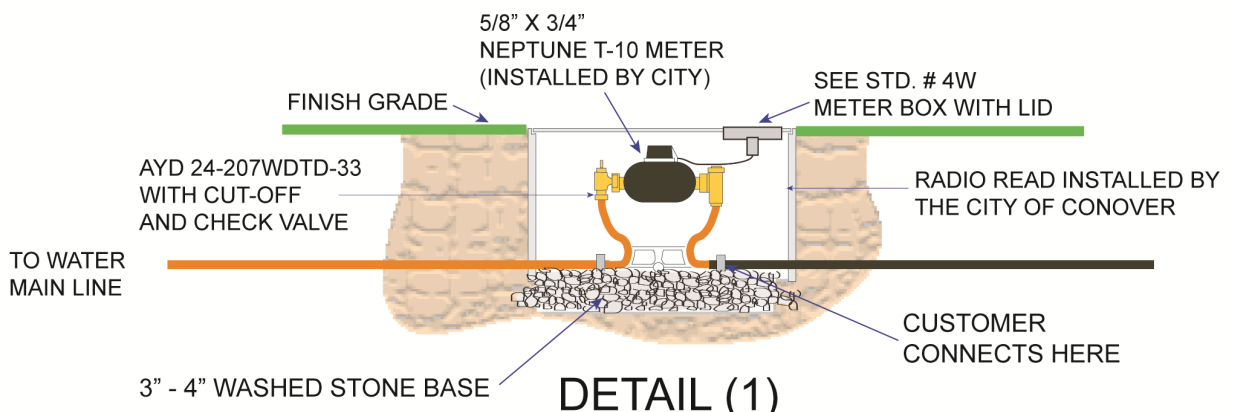

DETAIL (1)



STANDARD # 102W

CITY OF CONOVER
PUBLIC UTILITIES DEPARTMENT

TYPICAL DESIGN STANDARDS
SINGLE 1" SERVICE CONNECTION
SERVING 2 METERS

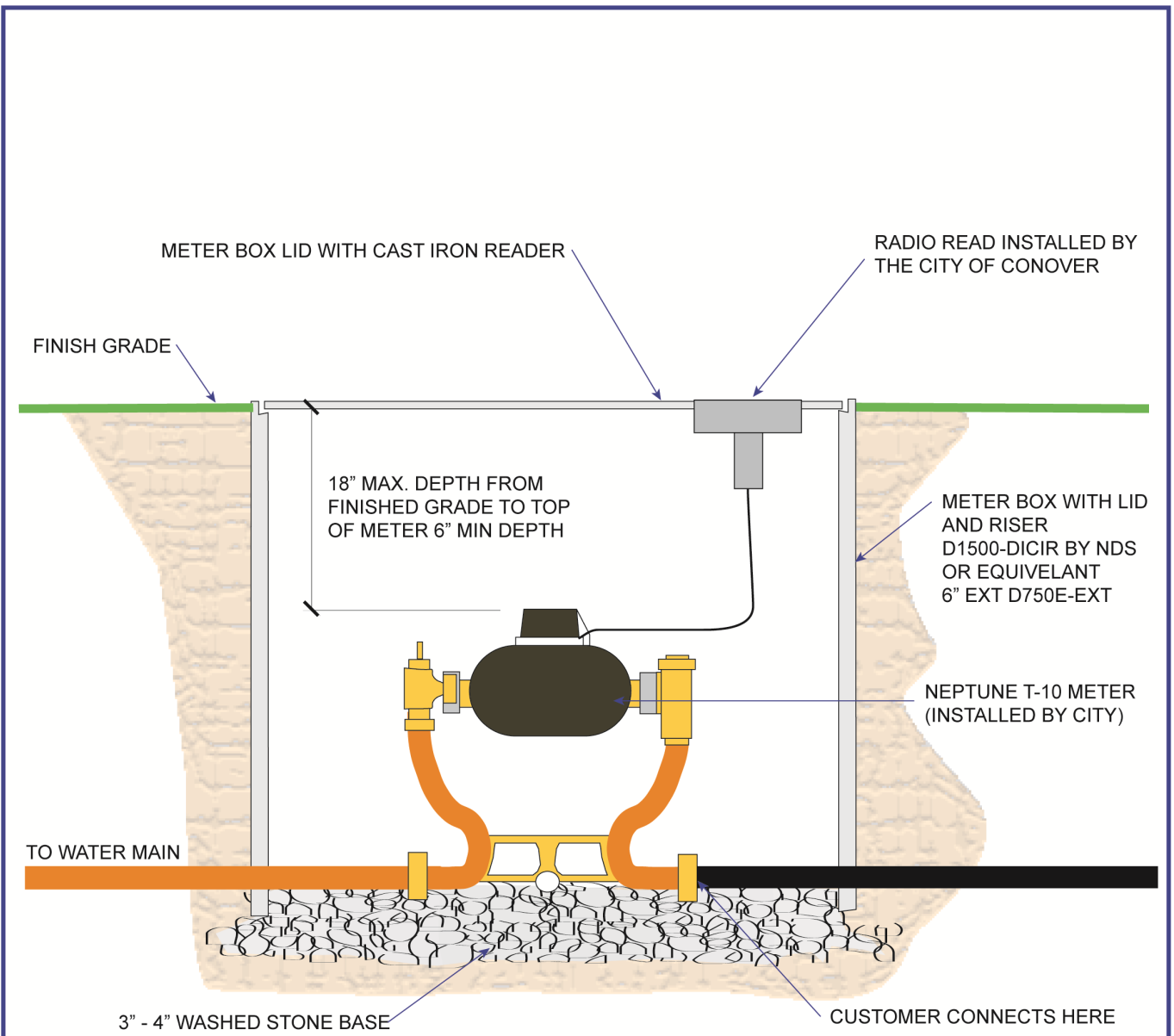

METER LOCATIONS SHALL BE SET AT R/W AND SHALL NOT BE PLACED IN ANY DRIVEWAYS OR SIDEWALKS.

METER BOX DETAIL
3/4" X 5/8" AND 1" METERS



STANDARD # 103W

CITY OF CONOVER
 PUBLIC UTILITIES DEPARTMENT

TYPICAL DESIGN STANDARDS
METER BOX DETAIL FOR
3/4" X 5/8" AND 1" METERS

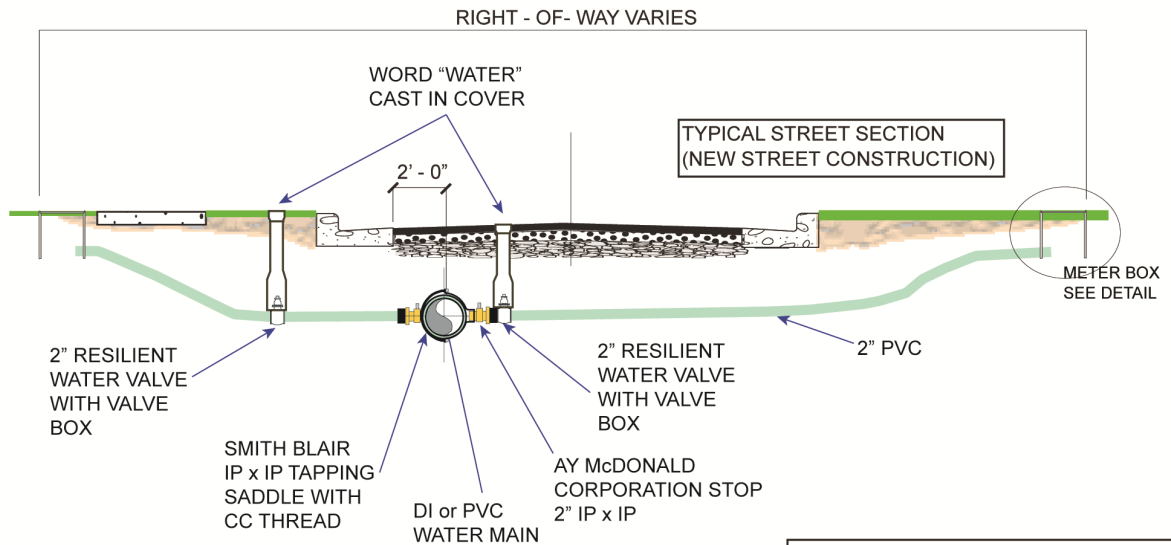

PROFILE
(SAME SIDE OPPOSITE SIDE SERVICE)

WHERE PAVEMENT EXISTS, ALL WATER SERVICES TO BE PUNCHED UNDER STREET. METER BOX LOCATIONS SHALL BE SET AT R/W AND SHALL NOT BE PLACED IN ANY DRIVEWAYS OR SIDEWALKS.

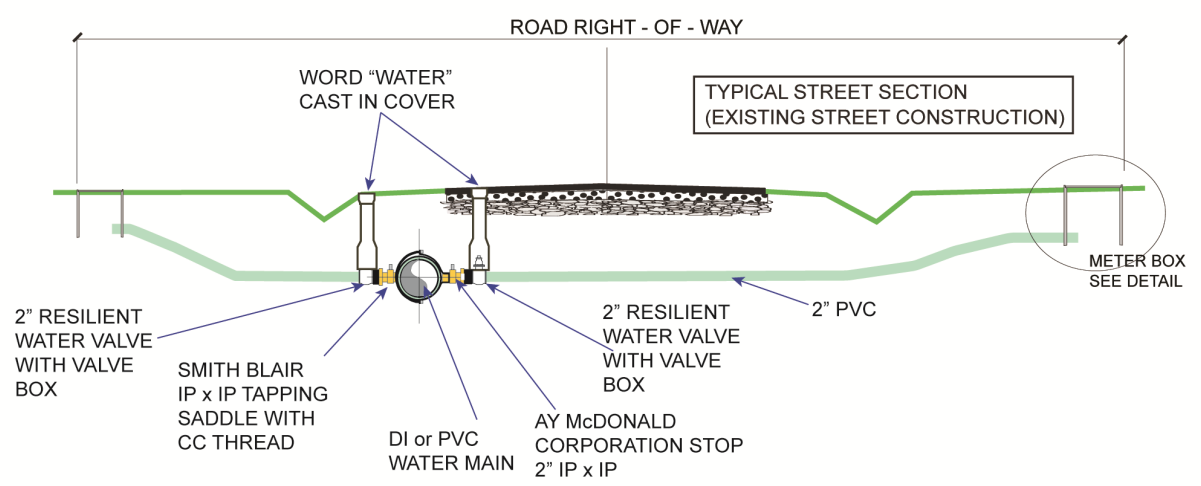

PROFILE
(SAME SIDE OPPOSITE SIDE SERVICE)

TYPICAL 2" WATER SERVICE CONNECTION TO PVC or DI WATER LINE



STANDARD # 104W

**CITY OF CONOVER
PUBLIC UTILITIES DEPARTMENT**

**TYPICAL DESIGN STANDARDS
2" WATER SERVICE CONNECTION
TO PVC or WATER LINE**

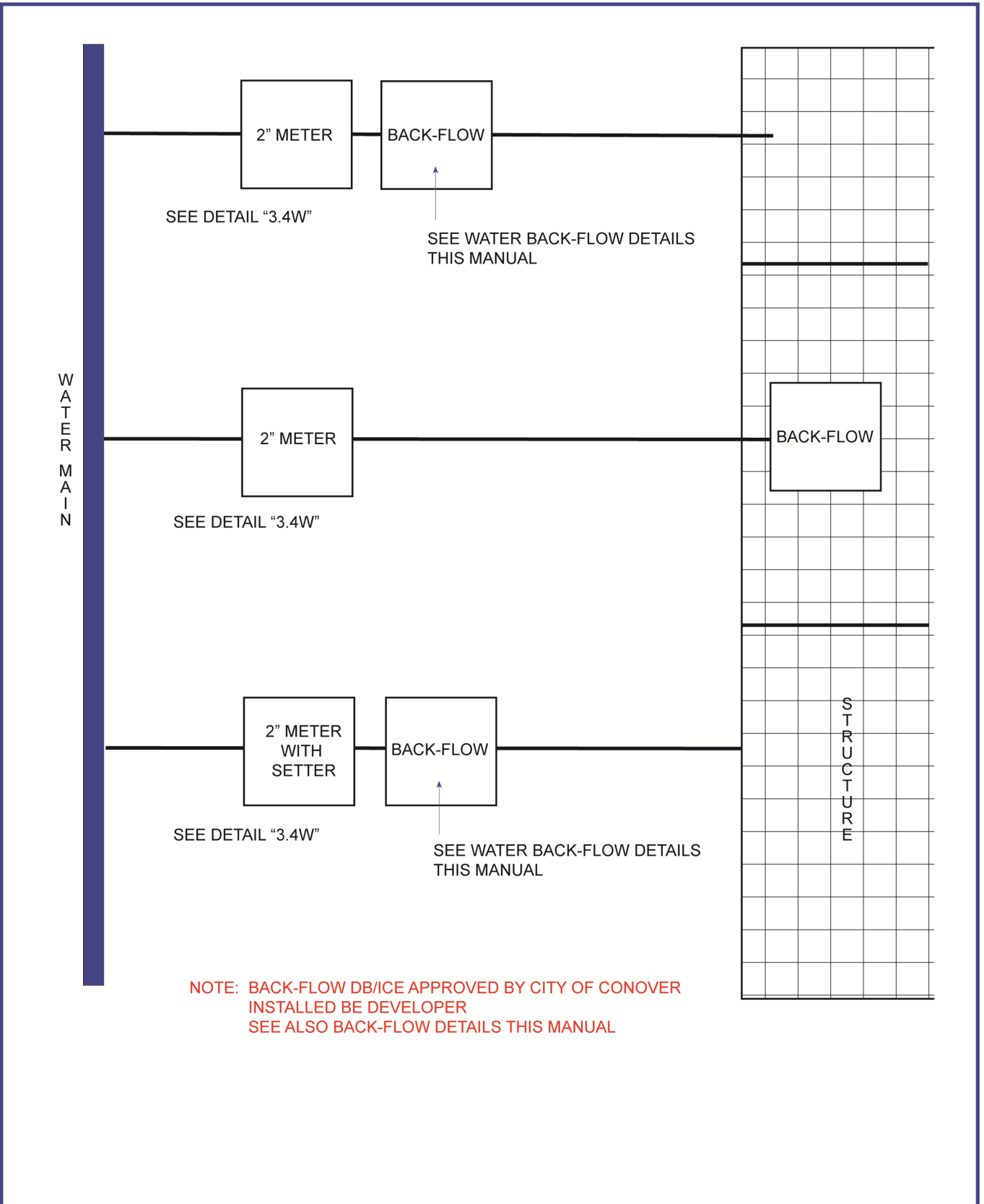

STANDARD # 105W

CITY OF CONOVER
PUBLIC UTILITIES DEPARTMENT

TYPICAL DESIGN STANDARDS
2" WATER SERVICE
CONNECTIONS

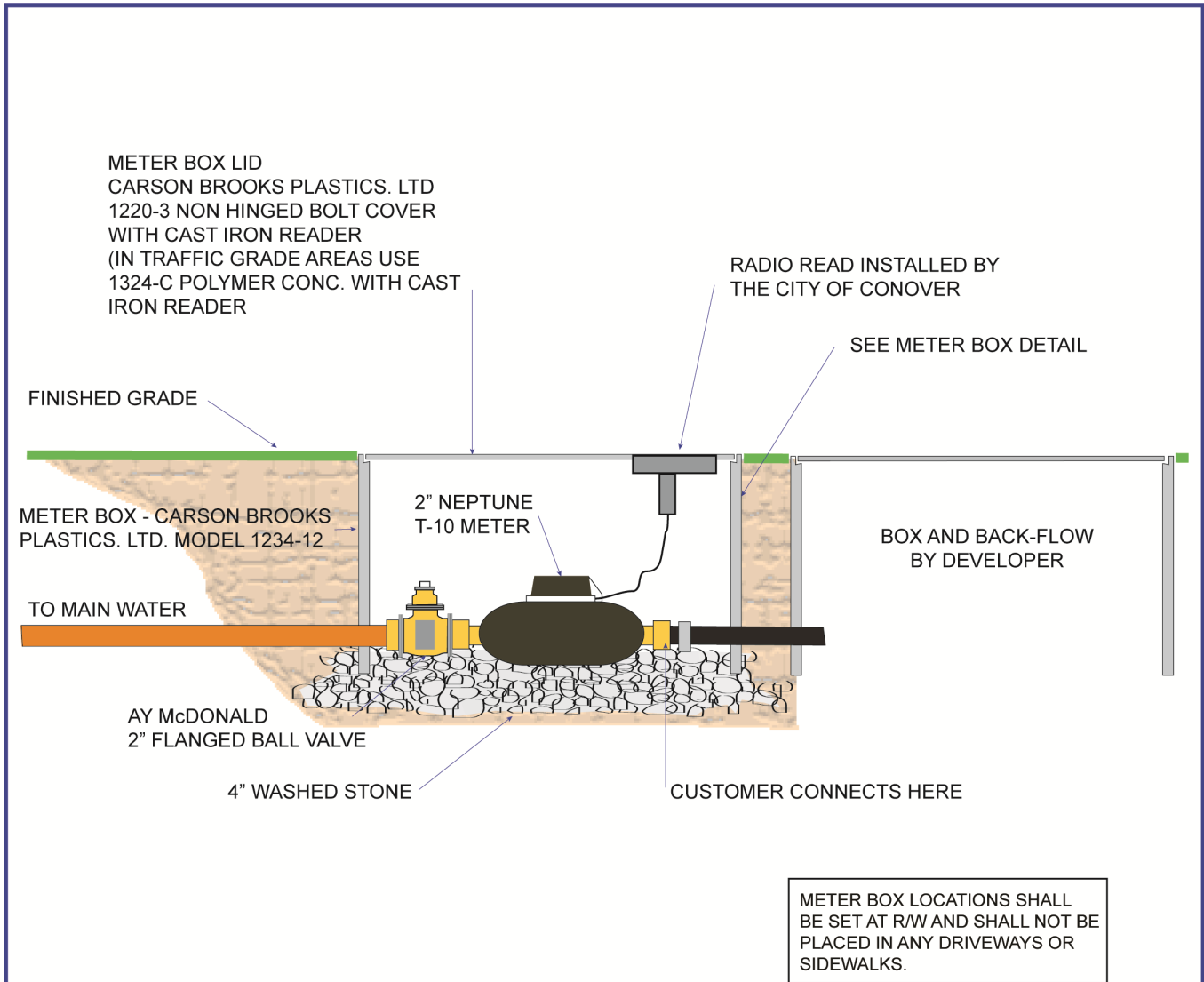

2" WATER SERVICE INSTALLATION

	<p>STANDARD # 106W</p>	<p>TYPICAL DESIGN STANDARDS 2" WATER SERVICE CONNECTIONS</p>
<p>CITY OF CONOVER PUBLIC UTILITIES DEPARTMENT</p>		

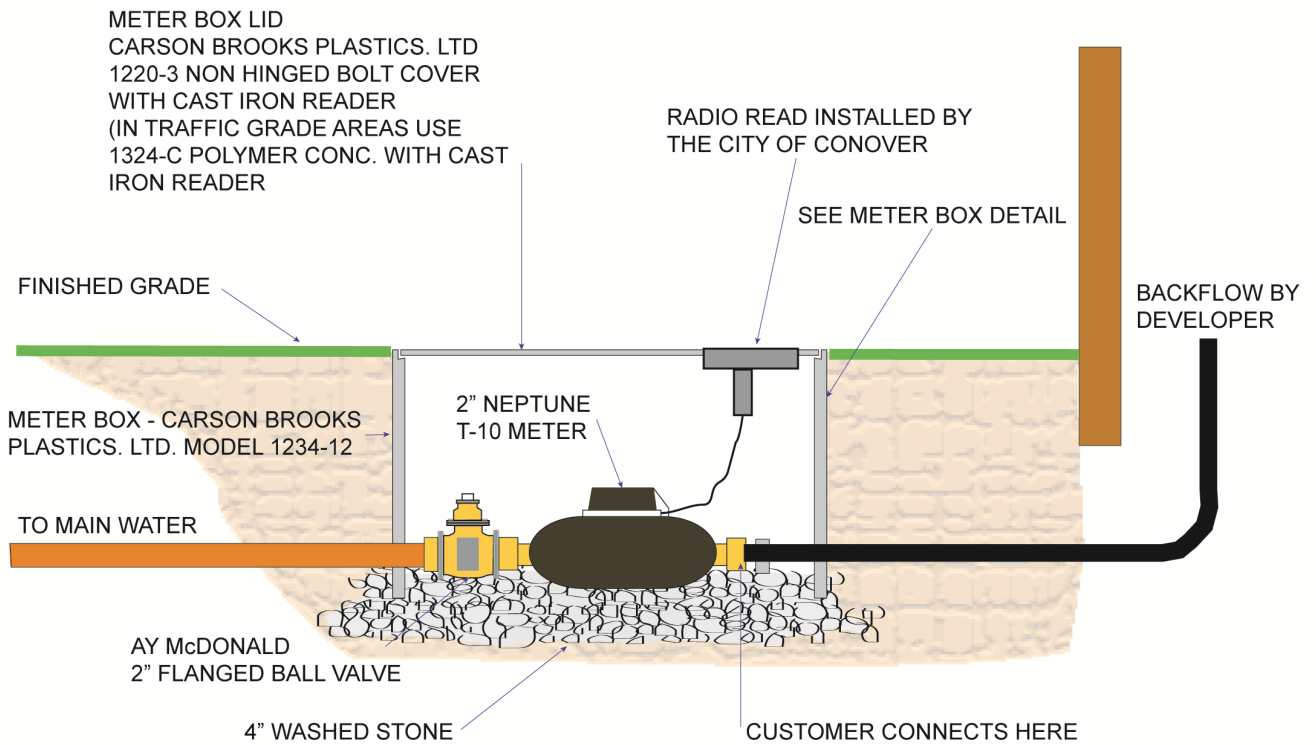

2" WATER SERVICE INSTALLATION



STANDARD # 107W

CITY OF CONOVER
PUBLIC UTILITIES DEPARTMENT

TYPICAL DESIGN STANDARDS
2" WATER SERVICE INSTALLATION

METER BOX LID - CAST IRON
 METER BOX WITH LID
 MBX-5A MANUFACTURED
 BY SIGMA CORPORATION

2" NEPTUNE T-10 METER
 (INSTALLED BY CITY)

RADIO READ INSTALLED BY
 THE CITY OF CONOVER

FINISH GRADE

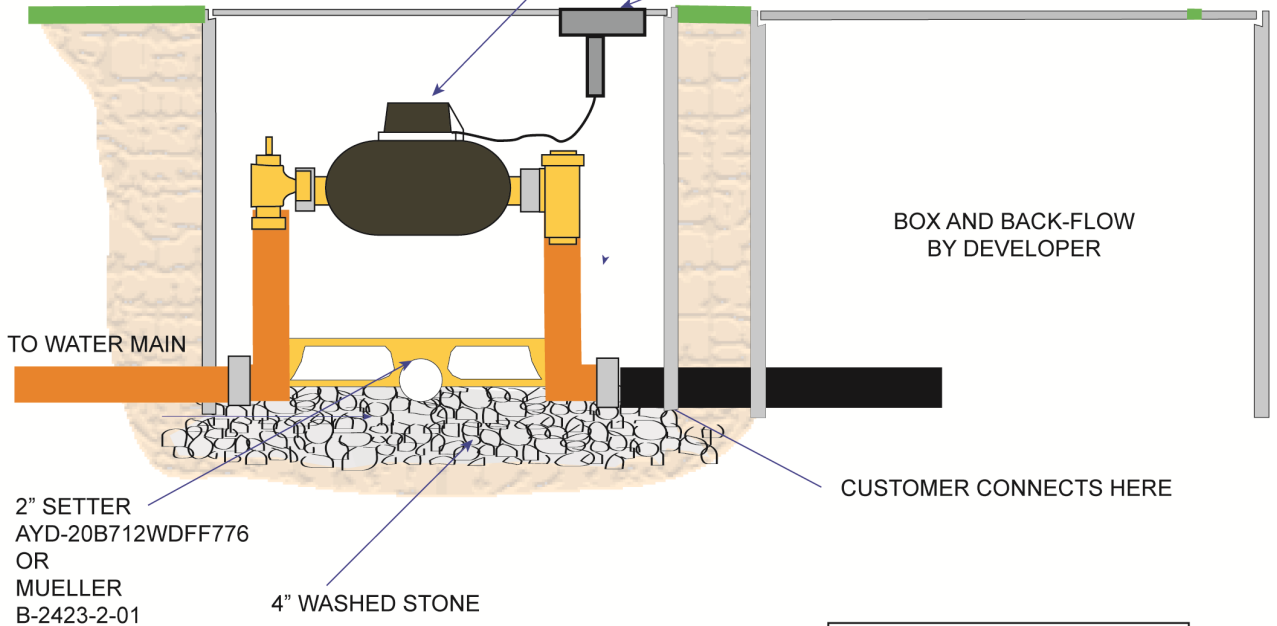

BOX AND BACK-FLOW
 BY DEVELOPER

TO WATER MAIN

CUSTOMER CONNECTS HERE

2" SETTER
 AYD-20B712WDFF776
 OR
 MUELLER
 B-2423-2-01

4" WASHED STONE

METER BOX LOCATIONS SHALL
 BE SET AT R/W AND SHALL NOT BE
 PLACED IN ANY DRIVEWAYS OR
 SIDEWALKS.

2" METER INSTALLATION WITH SETTER INSTALLATION



STANDARD # 108W

CITY OF CONOVER
 PUBLIC UTILITIES DEPARTMENT

TYPICAL DESIGN STANDARDS
 2" METER INSTALLATION
 WITH SETTER

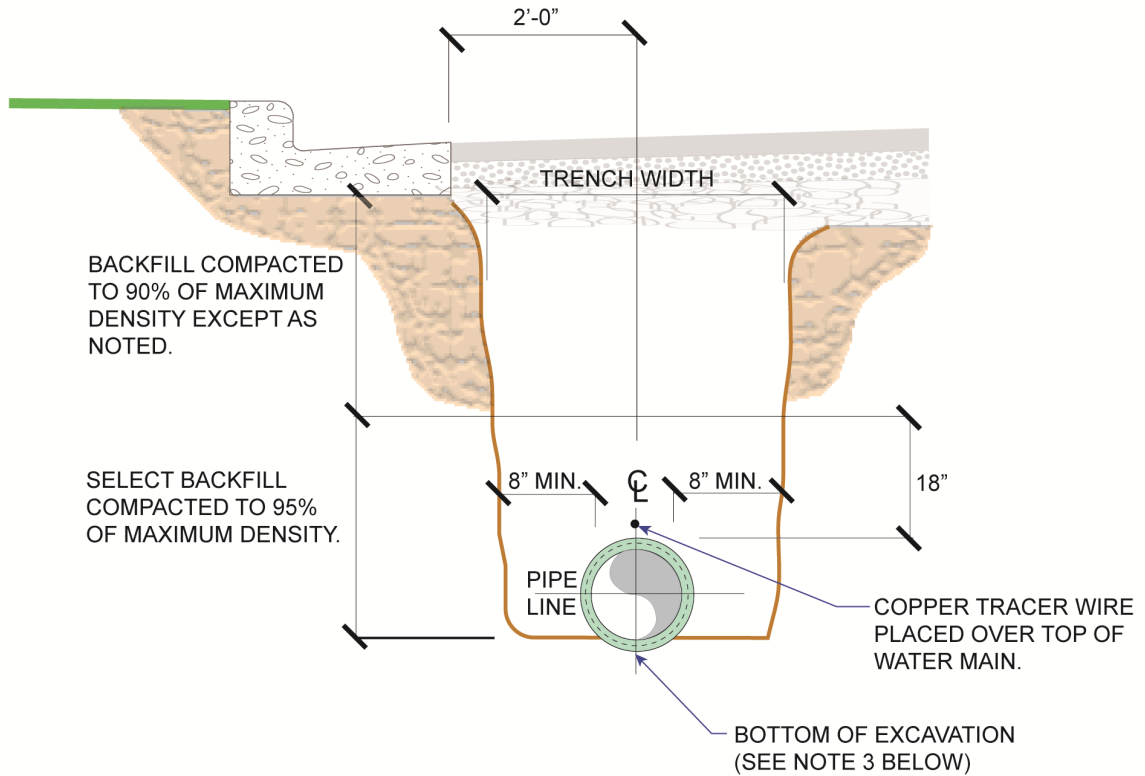

NOTES:

1. BACKFILL TO 95% OF MAXIMUM DENSITY WHERE EXCAVATION CUT THROUGH PAVEMENTS, CURBS DRIVEWAYS AND SIDEWALKS, AND UNDER OR ADJACENT TO STRUCTURES.
2. STONE TO BE SIZE 1/2" TO 1-1/2", WELL TAMPED.
3. STONE IS REQUIRED TO 6" MIN. BELOW PIPE WHERE WET CONDITIONS OR ROCK IS ENCOUNTERED, ONLY AS DIRECTED.
4. HAND SHAPE TRENCH BOTTOM FOR LOWER QUADRANT OR PIPE AND BELL.
5. PROVIDE MINIMUM 3'-0" COVER OVER PIPE.
6. TYPICAL WATER LINE TRENCH DETAIL FOR DUCTILE IRON MAINS.

STANDARD PVC WATER LINE TRENCH



STANDARD # 109W

CITY OF CONOVER
PUBLIC UTILITIES DEPARTMENT

TYPICAL DESIGN STANDARDS
STANDARD PVC WATER LINE
TRENCH

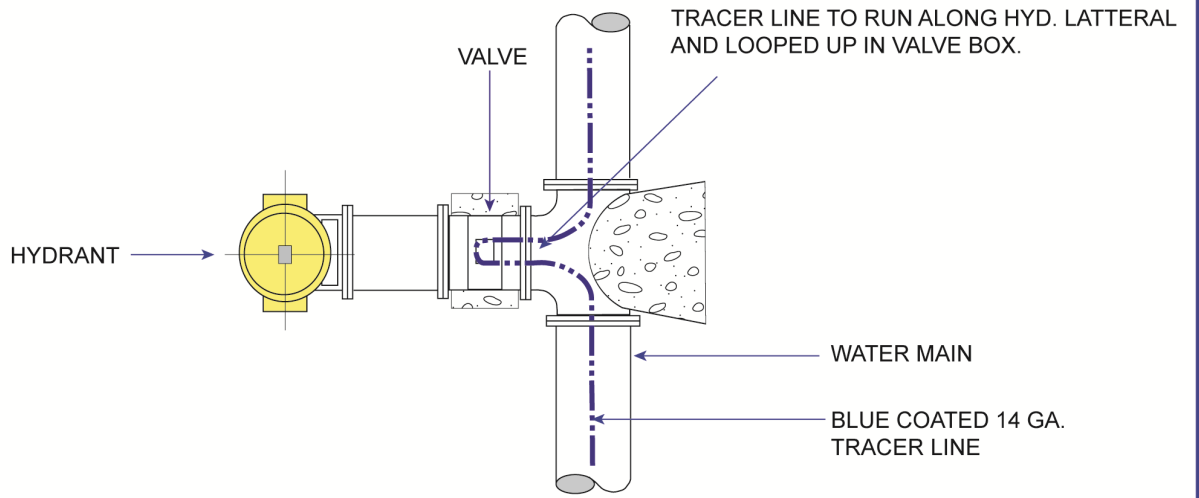

PLAN

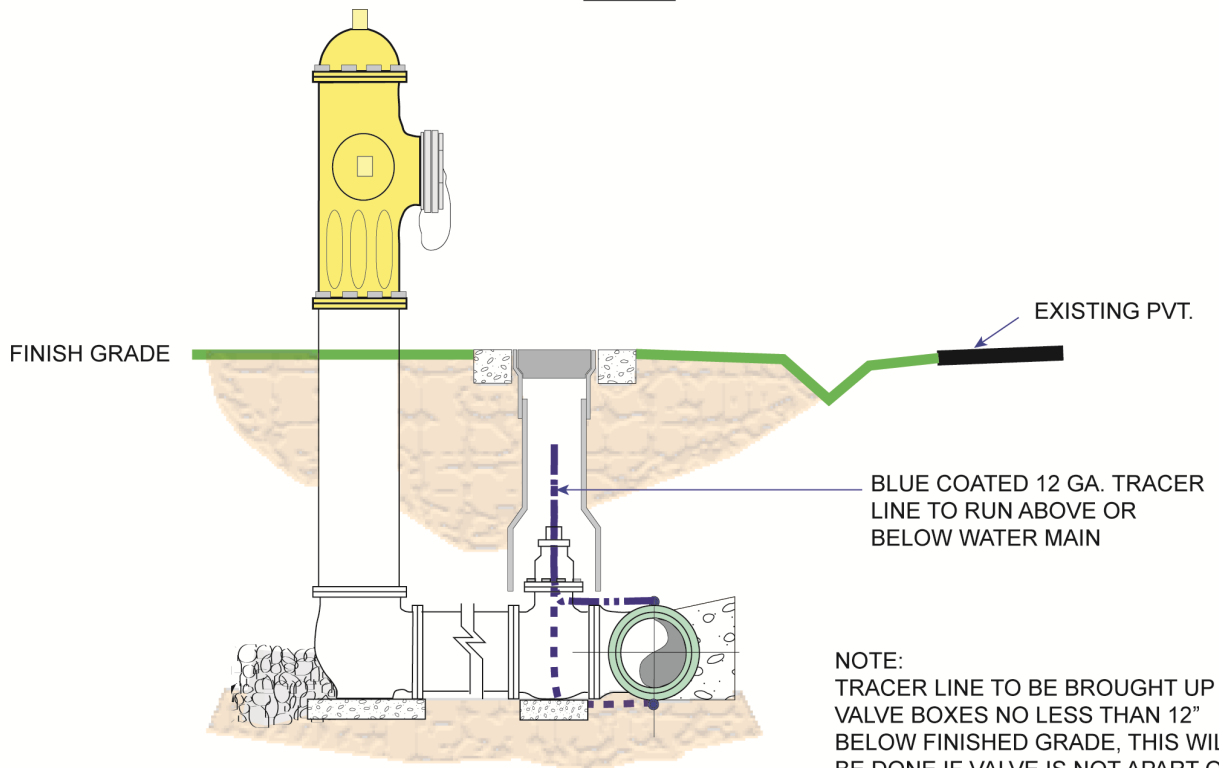

NOTE:
TRACER LINE TO BE BROUGHT UP IN VALVE BOXES NO LESS THAN 12" BELOW FINISHED GRADE, THIS WILL BE DONE IF VALVE IS NOT A PART OF HYDRANT ASSEMBLY.

ELEVATION

TRACER LINE DETAIL



STANDARD # 110W

CITY OF CONOVER
PUBLIC UTILITIES DEPARTMENT

TYPICAL DESIGN STANDARDS
TRACER LINE DETAIL

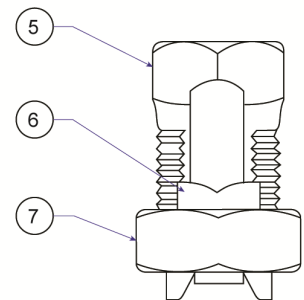
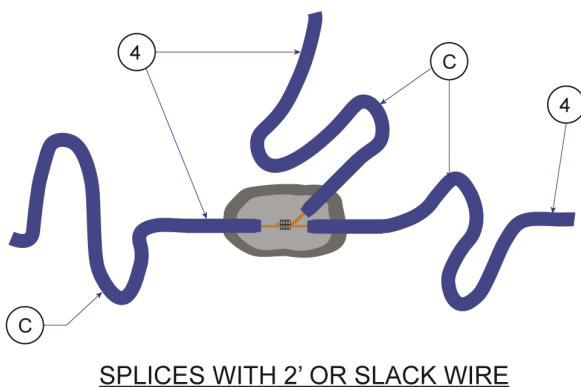
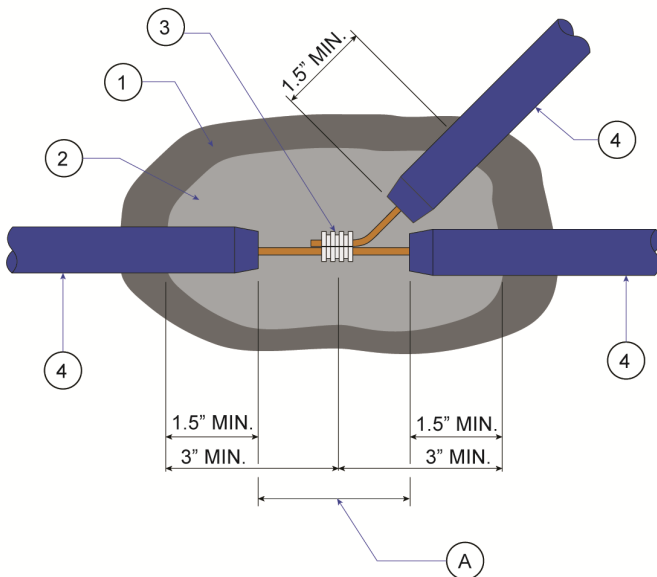
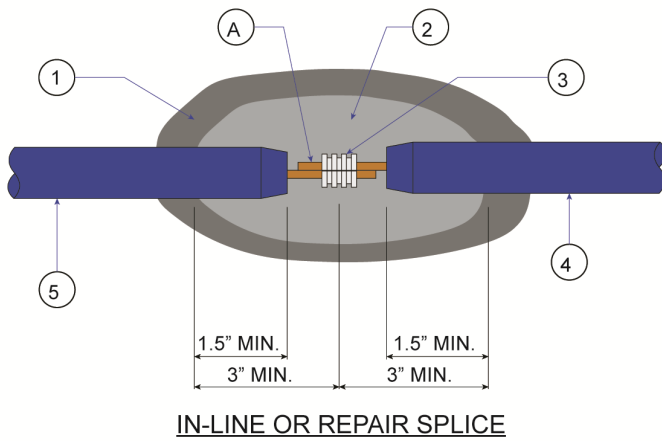

<u>NO.</u>	<u>DESCRIPTION</u>
1.	3-LAYERS OF HALF LAPPED VINYL TAPE.
2.	3-LAYERS OF HALF LAPPED RUBBER TAPE.
3.	COPPER CRIMP CONNECTOR OR COPPER ALLOY SPLIT BOLT CONNECTOR.
4.	SOLID COPPER WITH 30 MILS HDPE INSULATION (AWG #12 TRACER WIRE).
5.	SPLIT BOLT.
6.	PRESSURE BAR.
7.	HEX NUT.

NOTES:

- A. REMOVE MAINLINE TRACER WIRE INSULATION MATERIAL TO EXPOSE COPPER CORE WIRE.
- B. IN LINE SPLICES SHALL BE LIMITED TO THE GREATEST EXTENT POSSIBLE. TRACER WIRE SHALL BE AS CONTINUOUS AS POSSIBLE WITH SPLICES.
- C. SPLICES SHALL INCLUDE 2' OF SLACK WIRE ON EACH SIDE OF EACH SPLICE. (SEE DETAIL THIS SHEET)
- D. TRACER WIRE PLACEMENT NEXT TO PIPE FOR PIPE MATERIALS OTHER THAN HDPE. TRACER WIRE PLACEMENT IN RELATION TO HDPE PIPE IS UNDER PIPE IN CASE OF WEATHER.



STANDARD # 110W-1

**CITY OF CONOVER
PUBLIC UTILITIES DEPARTMENT**

**TYPICAL DESIGN STANDARDS
TRACER LINE SPLICE DETAIL**

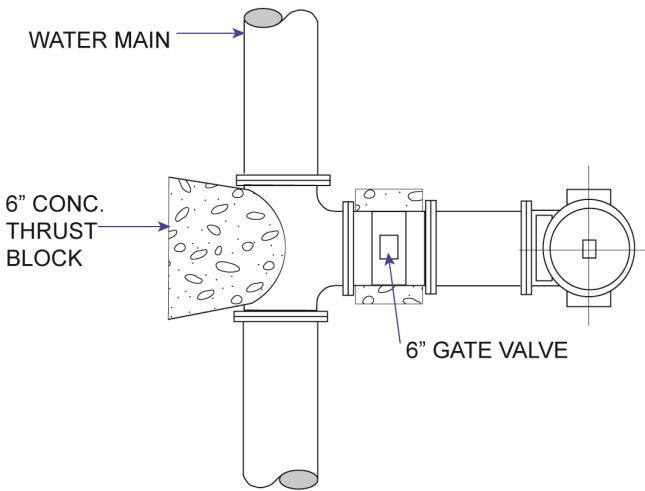

PLAN

NOTE:
 INSTALL PROPOSED FIRE HYDRANT A MINIMUM OF 4'-0" BEHIND EXISTING DITCH LINE OR 1'-0" OFF EXISTING R/W LINE. HYDRANTS AND VALVES SHALL NOT BE INSTALLED IN CONCRETE SIDEWALK OR CURB & GUTTER.

WHEN MAIN LINE IS CONSTRUCTED OF DUCTILE IRON, HYDRANT LEG SHALL BE DUCTILE IRON. MEGA LUGS CAN BE USED.

WHEN MAIN LINE IS CONSTRUCTED OF PVC, HYDRANT LEG SHALL BE PVC 3/4" ANCHOR RODS SHALL BE USED.

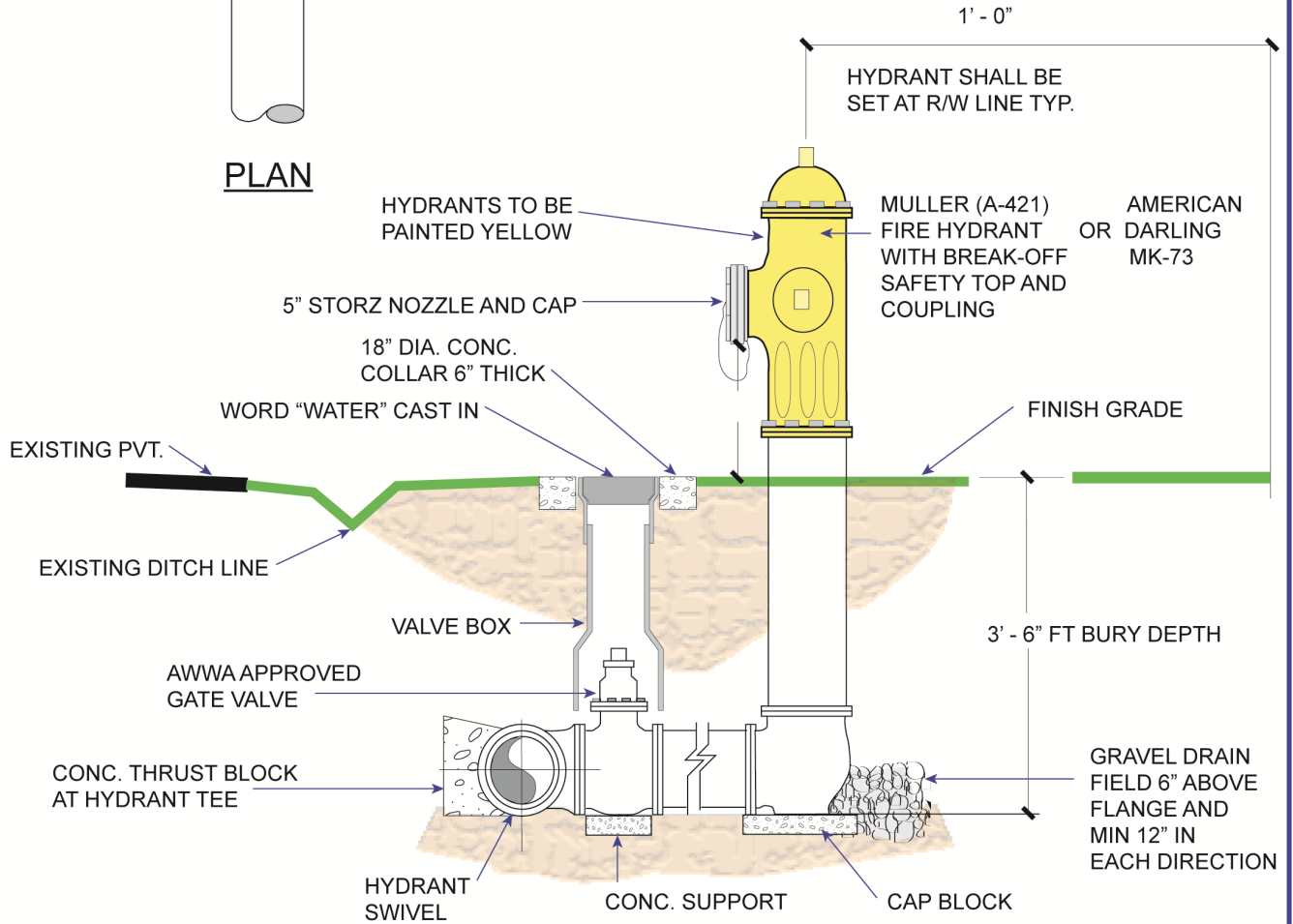

ELEVATION

STANDARD HYDRANT LATERAL



STANDARD # 111W

**CITY OF CONOVER
 PUBLIC UTILITIES DEPARTMENT**

**TYPICAL DESIGN STANDARDS
 STANDARD HYDRANT LATERAL**

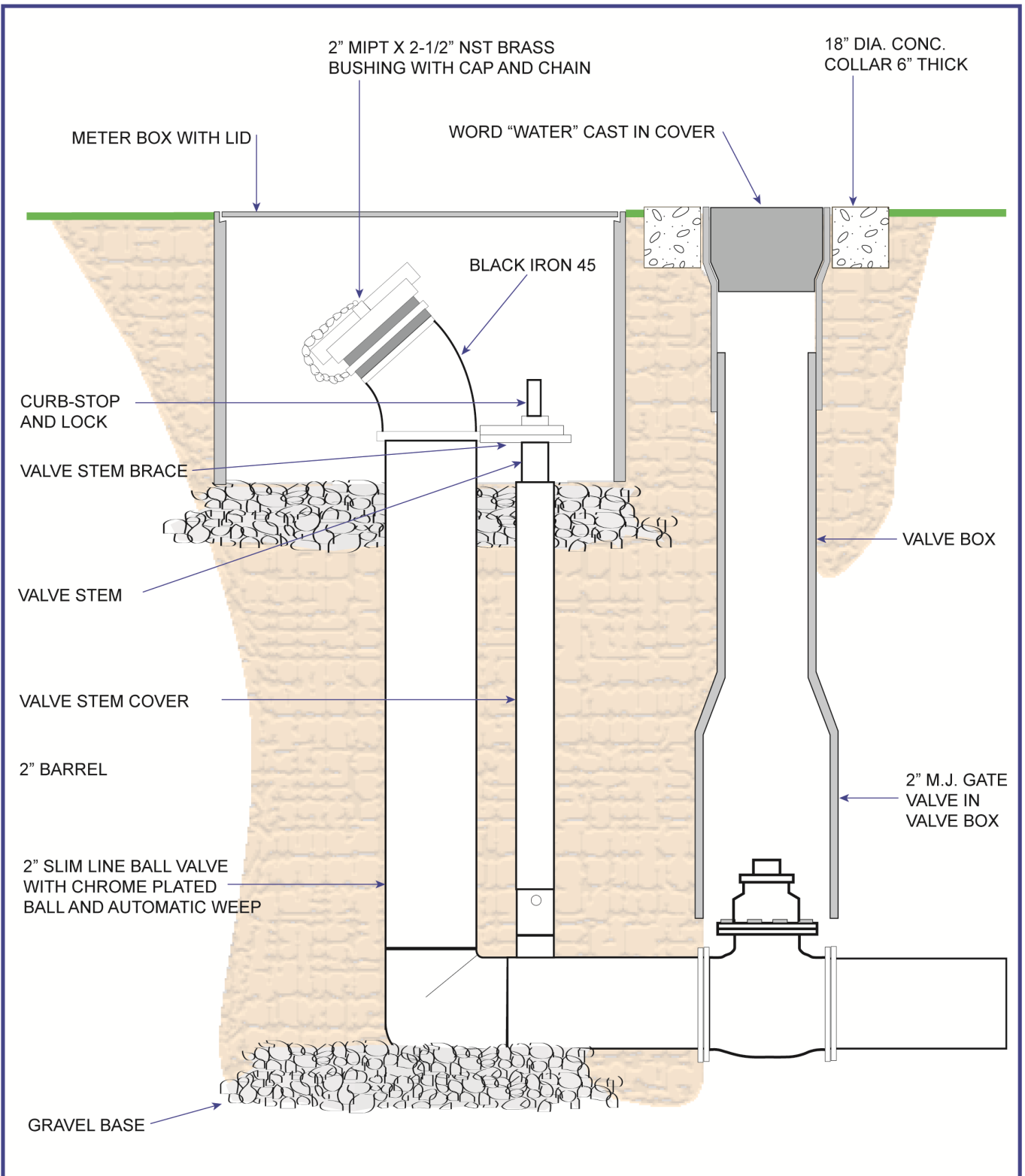

BELOW GROUND FLUSH TYPE FIRE HYDRANT



STANDARD # 112W

CITY OF CONOVER
PUBLIC UTILITIES DEPARTMENT

TYPICAL DESIGN STANDARDS
FLUSH TYPE FIRE HYDRANT
BLOW-OFF DETAIL

NOTES:

BLOW-OFF HYDRANTS SHALL BE ECLIPSE NO. 85 BOX HYDRANT. HYDRANTS SHALL BE SELF DRAINING, NON-FREEZING, COMPRESSION TYPE WITH 2-3/16" MAIN VALVE OPENING.
HYDRANT SHALL HAVE CAST IRON BOX, LOCKING LID AND 3" SCHEDULE 80 PVC RISER PIPE.
HYDRANTS SHALL BE SET IN 4 CUBIC FEET OF CRUSHED STONE TO ALLOW FOR PROPER DRAINAGE.

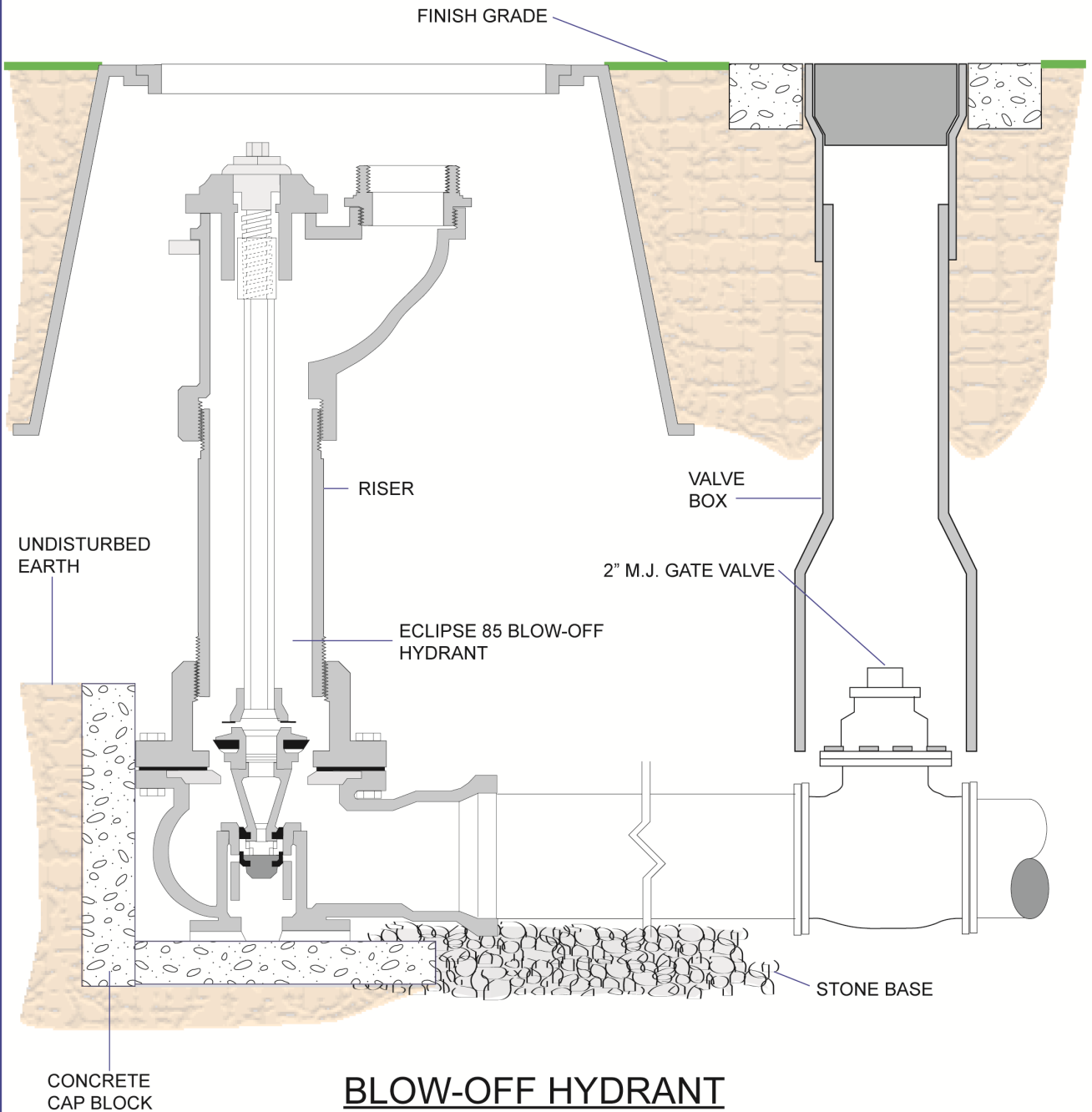

STANDARD # 113 W

**CITY OF CONOVER
PUBLIC UTILITIES DEPARTMENT**

**TYPICAL DESIGN STANDARDS
FLUSH TYPE FIRE HYDRANT
BLOW-OFF DETAIL**

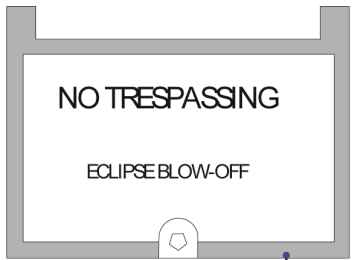

NOTES:
 BLOW-OFF HYDRANTS SHALL BE ECLIPSE NO. 85 BOX HYDRANT. HYDRANTS SHALL BE SELF DRAINING, NON-FREEZING, COMPRESSION TYPE WITH 2-3/16" MAIN VALVE OPENING.
 HYDRANT SHALL HAVE CAST IRON BOX, LOCKING LID AND 3" SCHEDULE 80 PVC RISER PIPE.
 HYDRANTS SHALL BE SET IN 4 CUBIC FEET OF CRUSHED STONE TO ALLOW FOR PROPER DRAINAGE.

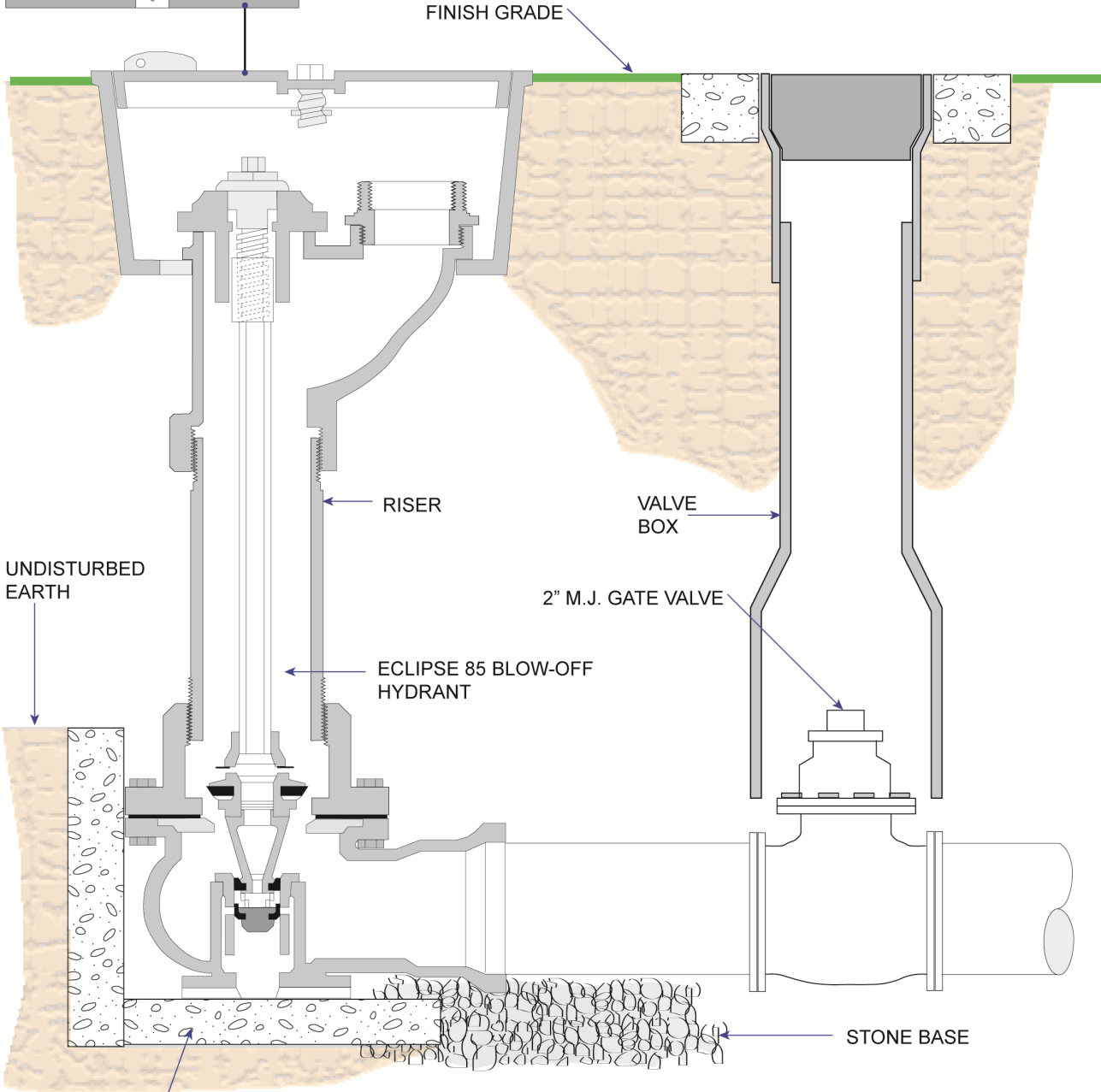

BLOW-OFF HYDRANT



STANDARD # 114W

CITY OF CONOVER
 PUBLIC UTILITIES DEPARTMENT

TYPICAL DESIGN STANDARDS
 FLUSH TYPE FIRE HYDRANT
 BLOW-OFF DETAIL

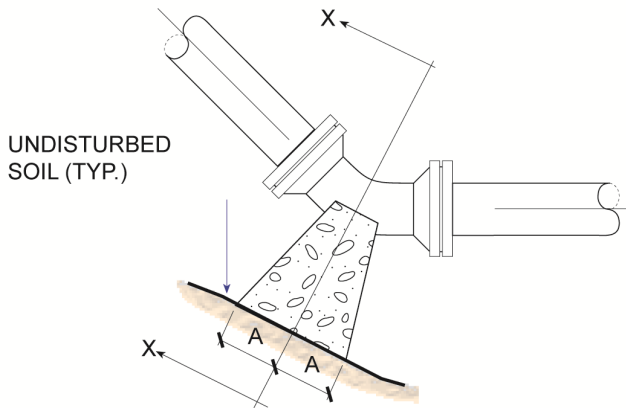

PLAN - BENDS

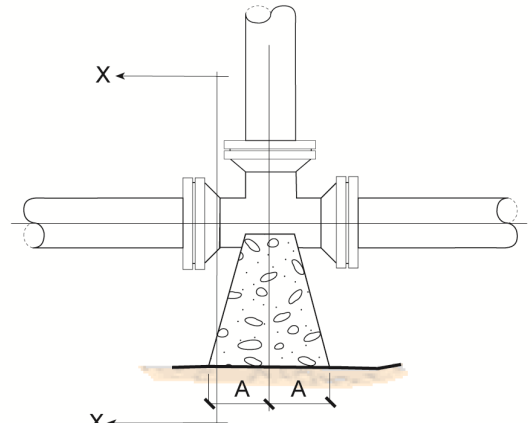

PLAN - TEES

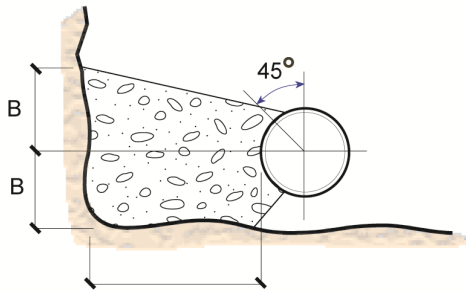

18" MIN. - 10" DIA. OR LESS
24" MIN. - 12" DIA. OR GREATER

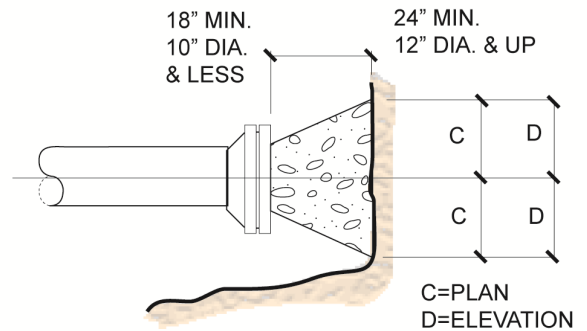

SECTION X-X BENDS AND TEES

PLAN & ELEVATION PLUGS

PIPE SIZE	90 BEND		45 BEND		22-1/2 BEND		11-1/4 BEND		TEE		PLUG	
	A	B	A	B	A	B	A	B	A	B	A	B
4"	18"	12"	10"	13"	7"	10"	7"	10"	12"	14"	13"	6"
6"	18"	12"	10"	13"	7"	10"	7"	10"	12"	14"	13"	6"
8"	24"	18"	13"	18"	10"	12"	10"	12"	16"	18"	25"	11"
10"	28"	22"	15"	22"	12"	15"	12"	15"	20"	22"	31"	14"
12"	32"	28"	19"	28"	14"	18"	14"	18"	22"	28"	37"	17"
16"	54"	38"	30"	36"	18"	36"	18"	36"	36"	42"	54"	24"

2000 PSF SOIL (SAND & GRAVEL WITH CLAY)

NOTES:

1. BASED ON 200 STATIC PRESSURE PLUS AWWA WATER HAMMER ALLOWANCE.
2. ALL BEARING SURFACES TO CARRIED TO UNDISTURBED GROUND.
3. THRUST BLOCKS TO BE USED AT ALL LINES OPERATING UNDER PRESSURE.
4. KEEP ALL PIPING JOINTS CLEAR OF CONCRETE THRUST BLOCKS.

THRUST BLOCKING DETAIL



STANDARD # 115W

**CITY OF CONOVER
PUBLIC UTILITIES DEPARTMENT**

**TYPICAL DESIGN STANDARDS
THRUST BLOCKING DETAIL**

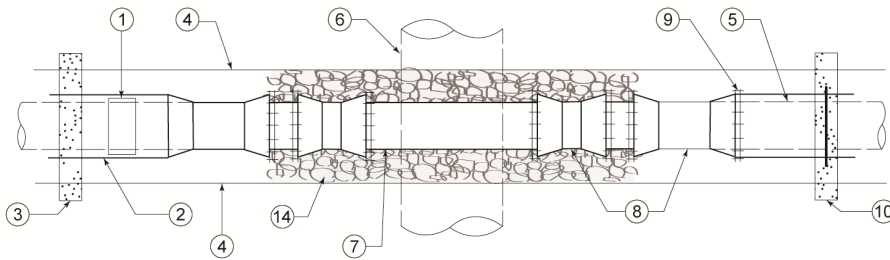

PLAN VIEW

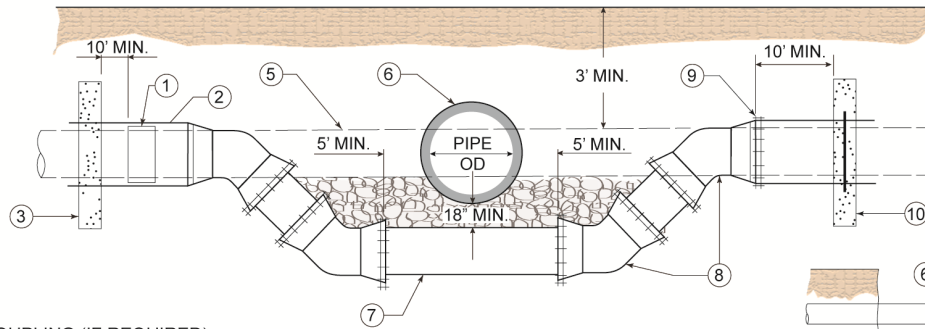

PROFILE VIEW

NO. DESCRIPTION

1. TRANSITION COUPLING (IF REQUIRED)
2. ROD VEND TO THRUST BLOCK
3. CONCRETE THRUST WALL BLOCKING
4. TRENCH LIMITS
5. EXISTING PIPE
6. STORM PIPE
7. NEW DUCTILE IRON PIPE WITH LENGTH CENTERED UNDER STORM DRAIN PIPE
8. 11.25 OR 22.5 RJ BENDS ROTATE AS REQUIRED
9. WEDGE ACTION RESTRAINT GLANDS
10. CONCRETE THRUST WALL BLOCKING WITH ANCHOR RING. SEE NOTE C
11. STIRRUPS (TYPICAL) SPACING 6" MINIMUM, 12" MAXIMUM
12. BEARING AREA
13. #4 BAR (TYPICAL)
14. BACKFILL WITH WASHED STONE (#57) BETWEEN TWO PIPES

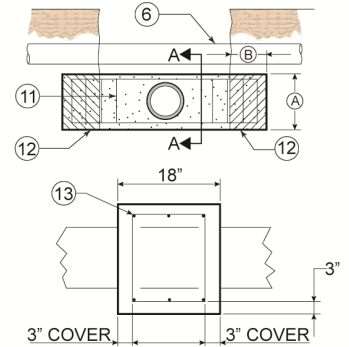

**SECTION A-A
THRUST BLOCK DETAIL**

NOTES:

- A. FITTINGS SHALL BE RESTRAINED USING WEDGE ACTION RESTRAINT, STAINLESS STEEL TIE RODS, OR RESTRAINED JOINT PIPE, AS APPROVED BY ENGINEER.
- B. BEARING AREAS (A X B) DETERMINED BY ACTUAL SOIL CONDITIONS. SHOULD BE BASED ON 200 PSI TEST PRESSURE SEE CHART BELOW.
- C. DO NOT USE ANCHOR RING ON PVC, CIP, OR AC PIPE. ANCHOR RING NOT REQUIRED IF THE TOP BEND IS RODDED.

RESULTANT THRUST AT FITTINGS AT 200 PSI WATER PRESSURE, TOTAL POUNDS.

NOM. PIPE DIAMETER	11.25 BEND	22.5 BEND
6 INCH	1466	2918
8 INCH	2522	5020
10 INCH	3793	7552
12 INCH	6364	10680

THE FOLLOWING OFTEN-USED VALUES FOR THE DEPTHS OF 4' ARE LISTED ONLY AS A GUIDE*. THE ENGINEER SHOULD SELECT THESE BEARING VALUES FOR EACH SOIL TYPE AND DEPTH OF COVER ENCOUNTERED ON THE SPECIFIC PIPELINE PROJECT. APPROPRIATE SAFETY FACTORS SHOULD BE APPLIED TO COVER FUTURE CHANGES IN PIPE DEPTH, SOIL BEARING CAPACITIES, ETC.

SOIL	BEARING LOAD (LBS/SQ. FT.)
MUCK	0
SOFT CLAY	1,000
SILT	1,500
SANDY SILT	3,000
SAND	4,000
SANDY CLAY	6,000
HARD CLAY	9,000

*NO RESPONSIBILITY CAN BE ASSUMED FOR THE ACCURACY OF THE DATA IN THIS TABLE DUE TO THE WIDE VARIATION OF BEARING LOAD CAPABILITIES FOR EACH SOIL TYPE



STANDARD # 116 W

**CITY OF CONOVER
PUBLIC UTILITIES DEPARTMENT**

**TYPICAL DESIGN STANDARDS
LOWERING OF 6-INCH TO 12-INCH
WATER MAIN**

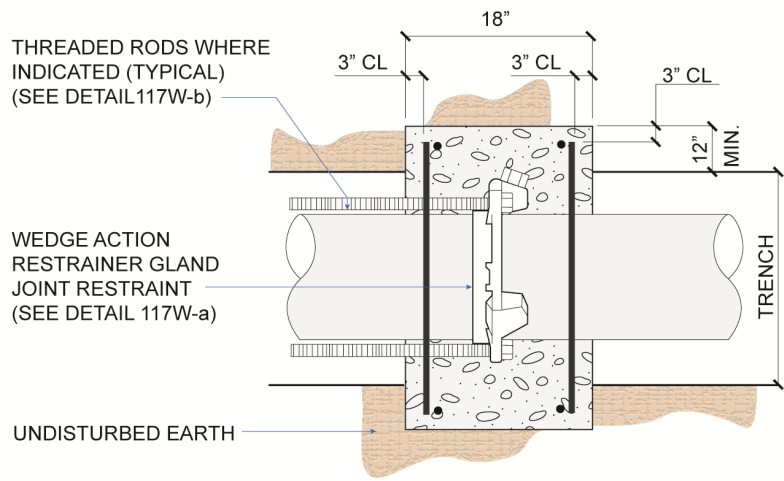

TOP SECTION VIEW

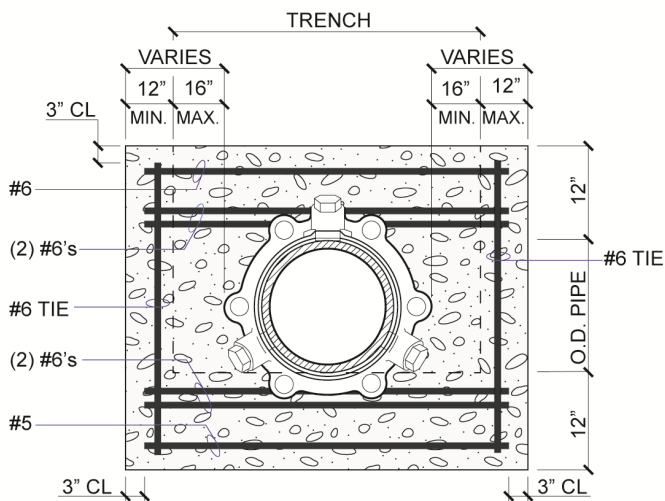

ELEVATION VIEW

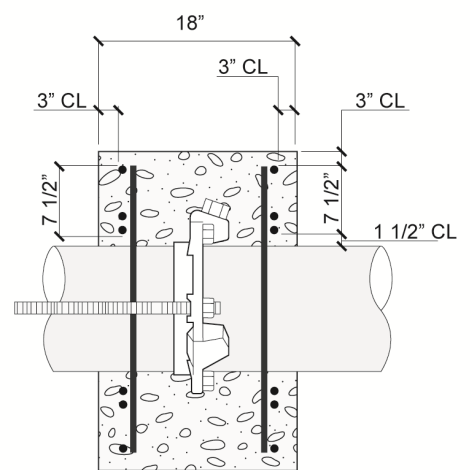

SIDE SECTION VIEW

NOTES:

1. REINFORCING SHALL BE 3000 P.S.I.
2. REINFORCING BARS SHALL BE DEFORMED BARS, AND TIED TOGETHER.
3. TRENCH BOTTOM WIDTH IN VICINITY OF THRUST BLOCK(S) INSTALLATION SHALL BE THE MINIMUM WIDTH FOR PLACEMENT OF PIPE (MAX TRENCH WIDTH = PIPE O.D. + 2 FT.)
4. BACKFILL AND COMPACT IN 6" LAYERS.
5. PLACE THRUST COLLAR ON ONE FULL JOINT OF PIPE.
6. LAST JOINT OF PIPE WITH THRUST COLLAR TO BE MECHANICAL JOINT PIPE.
7. PLACE WEDGE ACTION RESTRAINER GLAND JOINT RESTRAINT 4 FEET FROM PLUG END OF PIPE.



STANDARD # 117 W

**CITY OF CONOVER
PUBLIC UTILITIES DEPARTMENT**

**TYPICAL DESIGN STANDARDS
DEADMAN DETAIL**

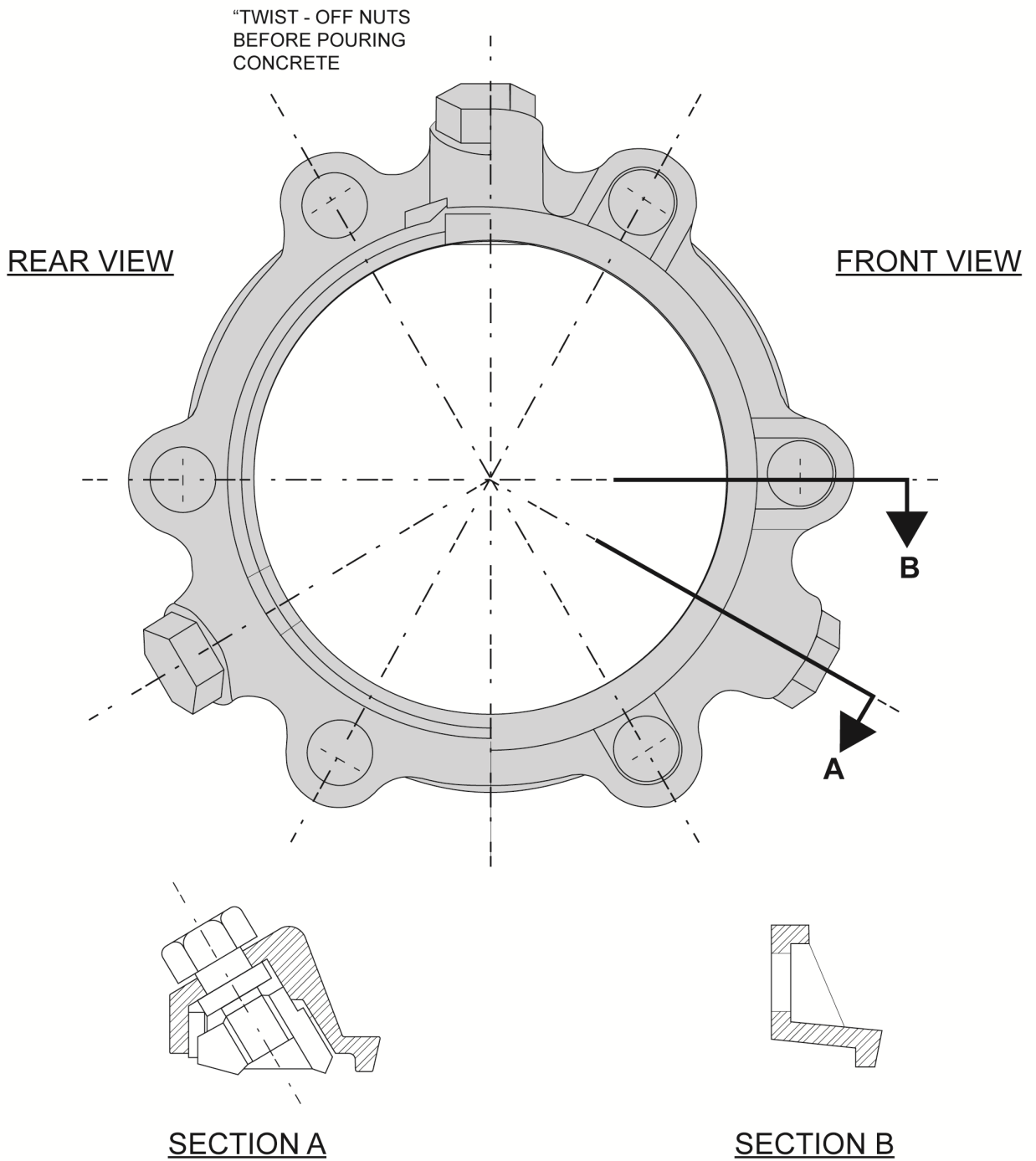

A MEG-A-LUG SERIES 1100 OR FORD WEDGE ACTION RESTRAINER GLAND UFR SERIES 1400 MECHANICAL JOINT RESTRAINT SHALL BE PLACED ON DIP AND PVC. CONCRETE AND REINFORCEMENT STEEL SHALL ALSO BE AS SHOWN ON STANDARD 117W.



STANDARD # 117W-a

CITY OF CONOVER
PUBLIC UTILITIES DEPARTMENT

TYPICAL DESIGN STANDARDS
THRUST COLLAR & BLOCKING
WITH WEDGE ACTION
RESTRAINER GLAND

TIE ROD ANCHORS DATUM

PIPE SIZE (INCHES)	PIPE SIZE (INCHES)	PIPE SIZE (INCHES)
TEST PRESSURE = 150 PSI		
6	3/4"	2
8	3/4"	2
10	3/4"	2
12	3/4"	4
16	3/4"	6
20	3/4"	8
24	3/4"	8
30	1"	10
TEST PRESSURE = 200 PSI		
6	3/4"	2
8	3/4"	2
10	3/4"	4
12	3/4"	6
16	3/4"	8
20	3/4"	12
24	3/4"	10
30	1"	14
TEST PRESSURE = 250 PSI		
6	3/4"	4
8	3/4"	4
10	3/4"	4
12	3/4"	6
16	3/4"	12
20	3/4"	14
24	3/4"	16
30	1"	20

ASTM A307 CADMIUM COATED TIE RODS



STANDARD # 117W-b

CITY OF CONOVER
PUBLIC UTILITIES DEPARTMENT

TYPICAL DESIGN STANDARDS
TIE ROD ANCHORS
DATUM CHART

(W) WATER AND (S) SEWER SHALL BE ETCHED IN FACE OF CURB FOR THE LOCATIONS OF THESE UTILITIES, METER BOXES AND SEWER CLEAN-OUTS

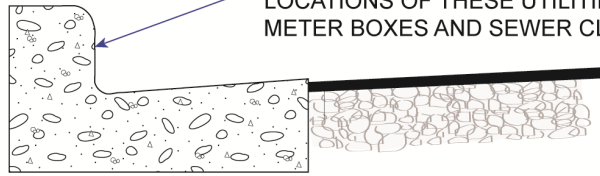

CURB & GUTTER ETCHING PLAN

(W) WATER AND (S) SEWER SHALL BE ETCHED IN FACE OF CURB FOR THE LOCATIONS OF THESE UTILITIES, METER BOXES AND SEWER CLEAN-OUTS

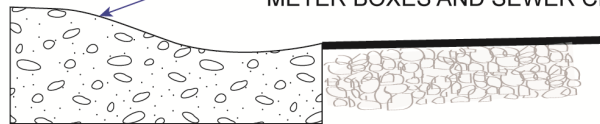

VALLEY CURB ETCHING

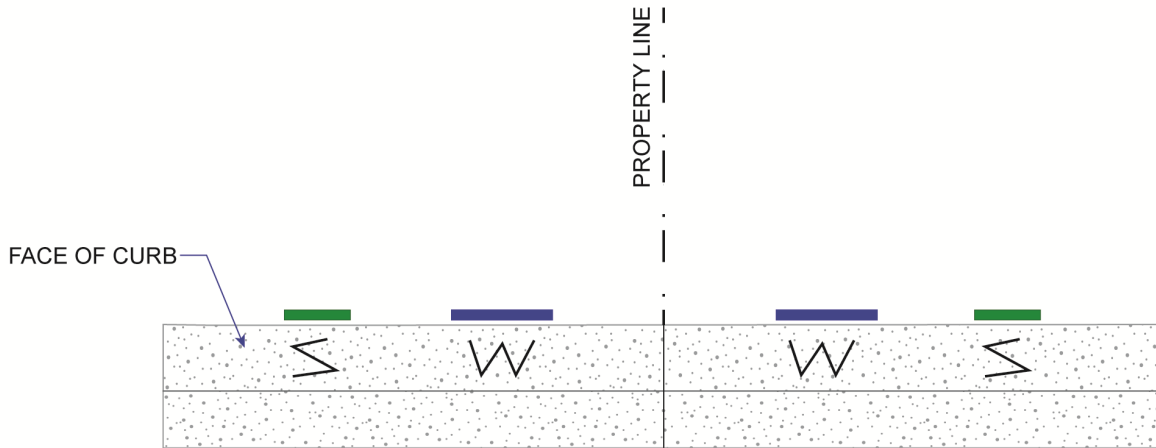

UTILITY ETCHING PLAN



STANDARD # 118 W

CITY OF CONOVER
PUBLIC UTILITIES DEPARTMENT

TYPICAL DESIGN STANDARDS
MARKINGS FOR WATER/SEWER
SERVICES

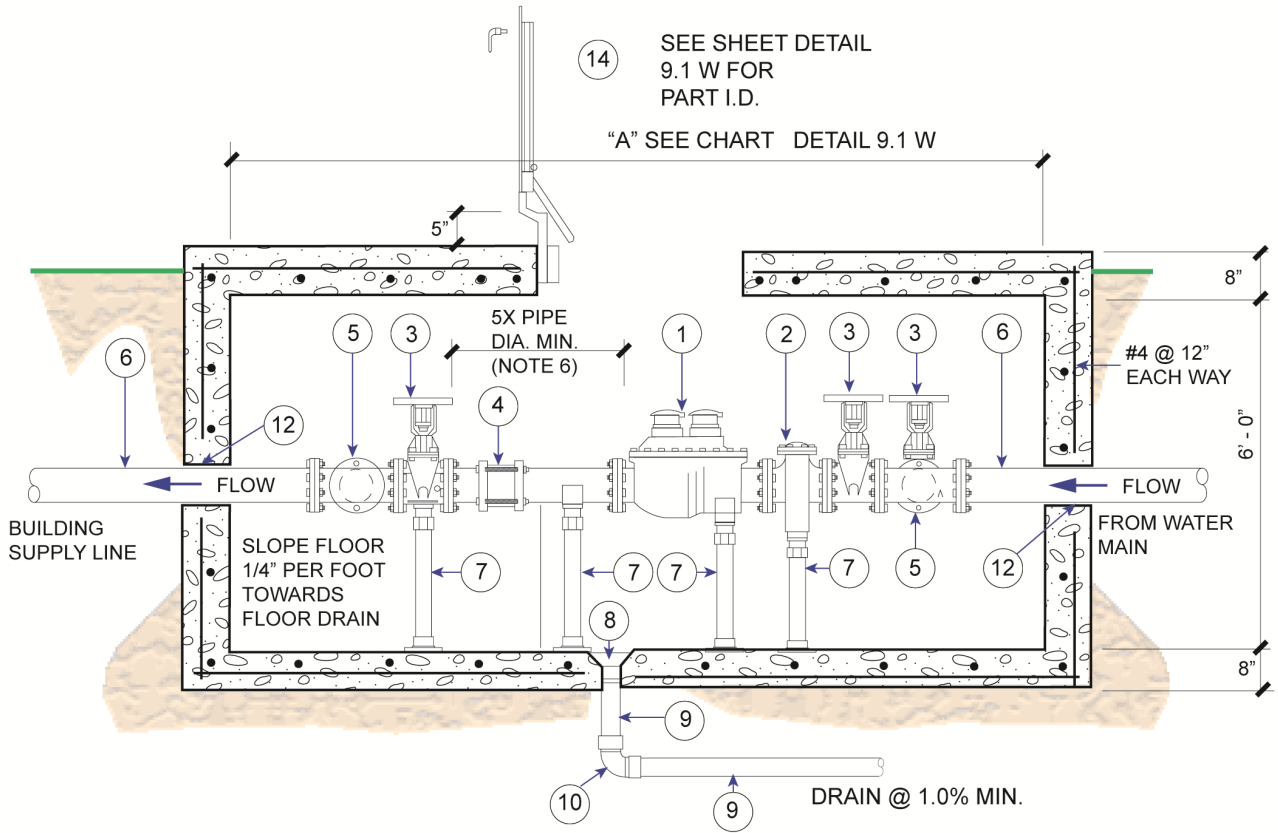

ELEVATION

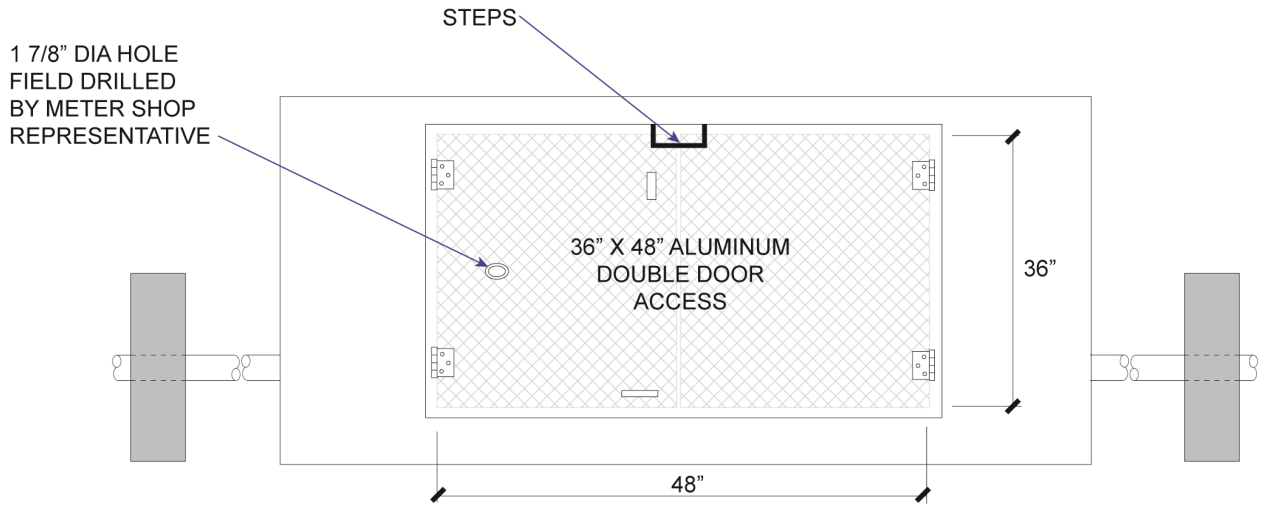

TOP



STANDARD # 200W

**CITY OF CONOVER
PUBLIC UTILITIES DEPARTMENT**

**UNDERGROUND METER VAULT
FOR 3 INCH AND LARGER**

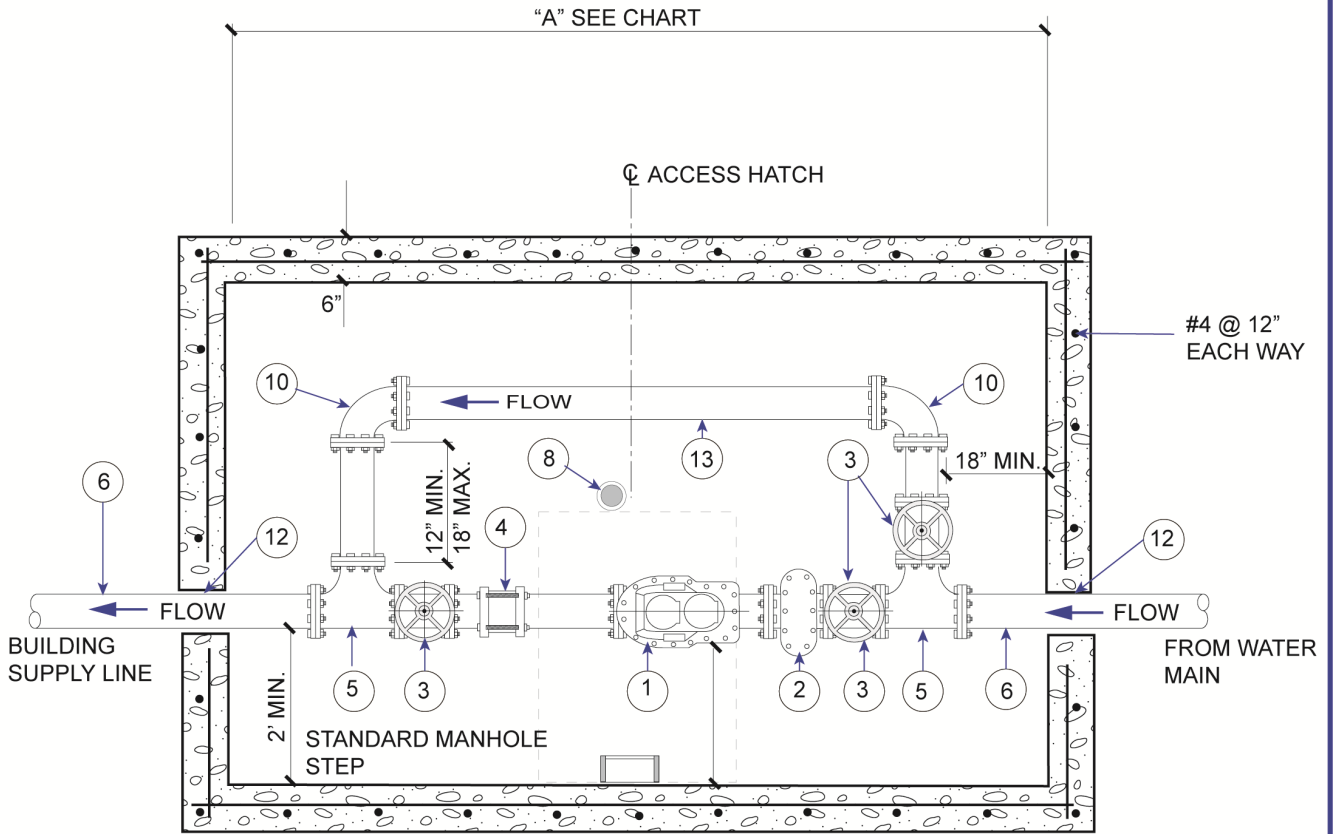

PLAN VIEW

NOTES:

1. COMPOUND OR TURBINE METER
2. STRAINER
3. GATE VALVE WITH RESILIENT SEATS
4. COUPLING
5. D.I.P. FLANGED TEE
6. (1) FULL JOINT D.I.P. FLANGE X PE (NOTE 3)
7. ADJUSTABLE PIPE SUPPORTS HOT DIPPED GALVANIZED
8. FLOOR DRAIN
9. D.I.P. CLASS 350 OR SCH 40 PIPE
10. D.I.P. 350 OR SCH 40 ELBOW
11. ALL SIZES AND TYPES TO BE APPROVED BY CITY OF CONOVER
12. WALL SLEEVE WITH LINK SEAL
13. 3" AND LARGER D.I.P. PIPE OR APPROVED EQUIVALENT
14. 36" X 48" HINGED FRAME DOUBLE ACCESS DOOR (SHEET #1)

CHART A

METER SIZE	VAULT SIZE
3"	4' X 8' X 6'
4"	6' X 8' X 6'
6"	8' X 10' X 6'

NOTE: ALL DIMENSIONS ARE INSIDE



STANDARD # 201W

**CITY OF CONOVER
PUBLIC UTILITIES DEPARTMENT**

**UNDERGROUND METER VAULT
FOR 3 INCH AND LARGER**

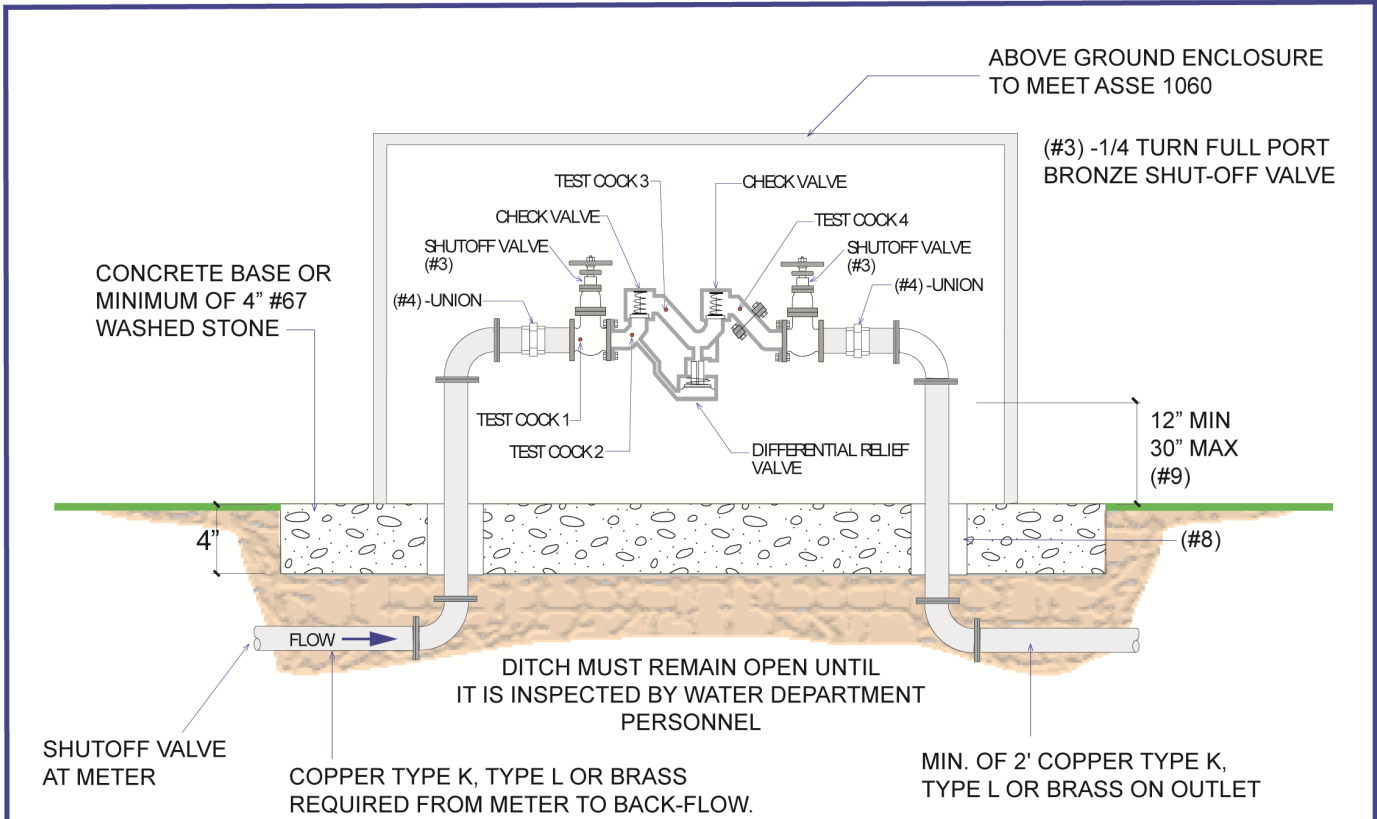

1. THE BACK-FLOW DEVICE SHALL BE WITHIN 10' OF AND ON THE PROPERTY SIDE OF THE METER UNLESS APPROVED BY THE CITY OF CONOVER.
2. ALL REDUCED PRESSURE BACK-FLOW DEVICES SHALL BE INSTALLED ABOVE GROUND IN A HORIZONTAL POSITION.
3. SHUT OFF VALVES SHALL BE FULL PORT, LINE SIZE AND 1.4 TURN BRONZE BALL VALVES.
4. DEVICES SHALL HAVE TWO RESILIENT SEAT BRONZE UNIONS OUTSIDE OF THE SHUT OFF VALVES.
5. THE DEVICE SHALL HAVE 4 TEST COCKS WITH ONE BEING INSTALLED ON THE CITY SIDE OF THE INLET BALL VALVE.
6. FLOOR DRAIN REQUIRED IF INSTALLED INSIDE OF BUILDING. SEE SPECIFICATIONS FOR PROPER SIZING.
7. TANDEM BACK-FLOWS REQUIRED IF SERVING MULTIPLE USERS OR SERVICE CANNOT BE INTERRUPTED.
8. 4" SLEEVE TO BE INSTALLED AROUND UPRIGHT WHEN INSTALLING IN CONCRETE PAD.
9. MINIMUM AND MAXIMUM DISTANCE OF DIFFERENTIAL RELIEF VALVE FROM BASE.

SIZES 3/4" - 2"
REDUCED PRESSURE BACK-FLOW PREVENTER
ABOVE GROUND INSTALLATION

	<p>STANDARD # 300WB</p> <p>CITY OF CONOVER PUBLIC UTILITIES DEPARTMENT</p>	<p>TYPICAL DESIGN STANDARDS REDUCED PRESSURE BACK-FLOW PREVENTER ABOVE GROUND 3/4" - 2" INSTALLATION</p>
---	--	---

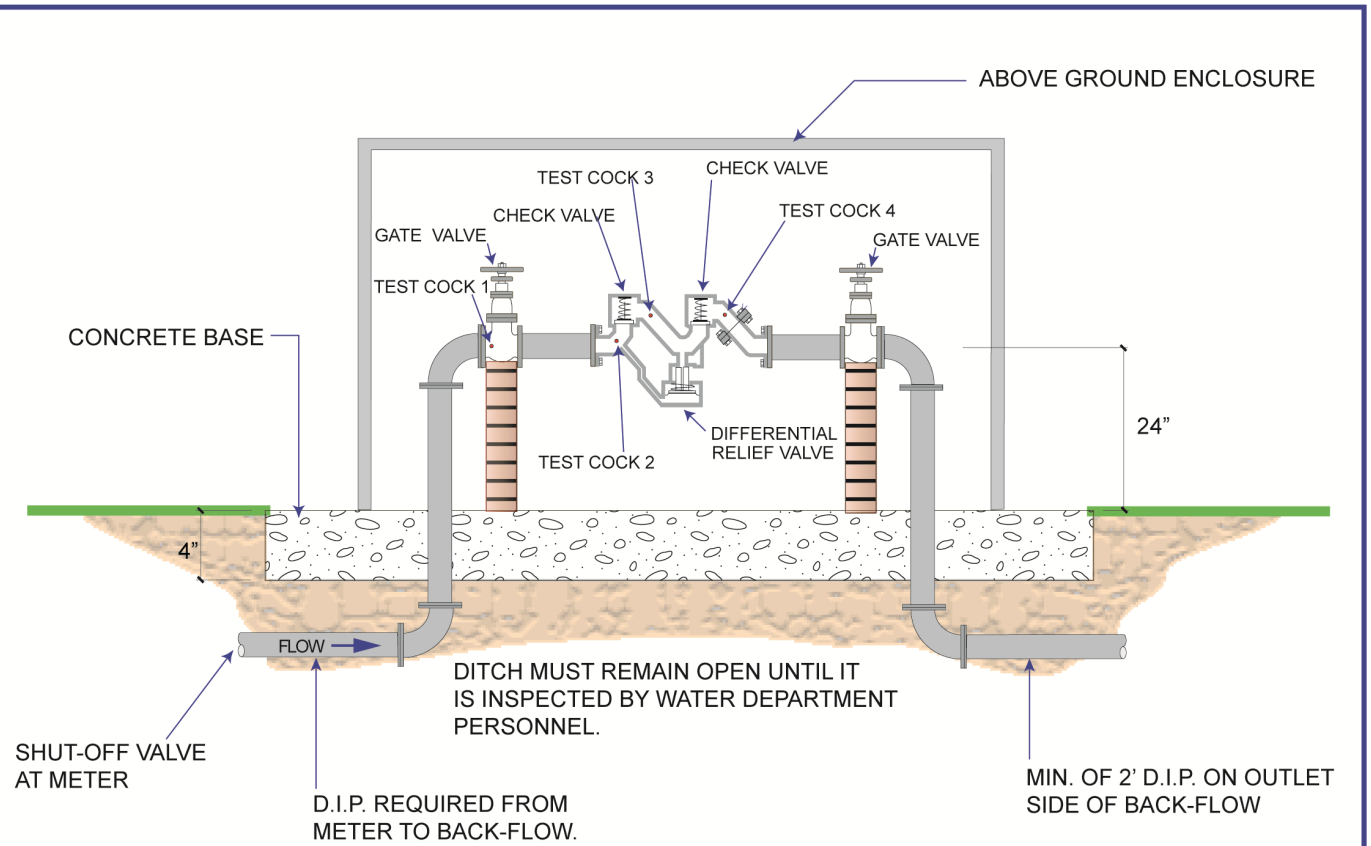

1. THE BACK-FLOW DEVICE SHALL BE WITHIN 10' OF AND ON THE PROPERTY SIDE OF THE METER UNLESS APPROVED BY THE CITY OF CONOVER.
2. ALL REDUCED PRESSURE BACK-FLOW DEVICES SHALL BE INSTALLED ABOVE GROUND IN A HORIZONTAL POSITION.
3. SHUT OFF VALVES SHALL BE RESILIENT SEAT WITH FLANGED ENDS AND HAND-WHEEL.
4. ALL INTERIOR AND EXTERIOR IRON SURFACES SHALL HAVE EPOXY COATINGS TO CONFORM TO ANSI / AWWA C550, OR MANUFACTURED OF STAINLESS STEEL.
5. THE DEVICE SHALL HAVE 4 TEST COCKS WITH ONE BEING INSTALLED ON THE CITY SIDE OF THE INLET GATE VALVE.
6. FLOOR DRAIN REQUIRED IF INSTALLED INSIDE OF BUILDING.
7. TANDEM BACK-FLOWS REQUIRED IF SERVING MULTIPLE USERS OR SERVICE CANNOT BE INTERRUPTED.

SIZES 3" - 8"
REDUCED PRESSURE BACK-FLOW PREVENTER
ABOVE GROUND INSTALLATION



STANDARD #301WB

CITY OF CONOVER
PUBLIC UTILITIES DEPARTMENT

TYPICAL DESIGN STANDARDS
REDUCED PRESSURE BACK-FLOW
PREVENTER ABOVE GROUND
3" - 8" INSTALLATION

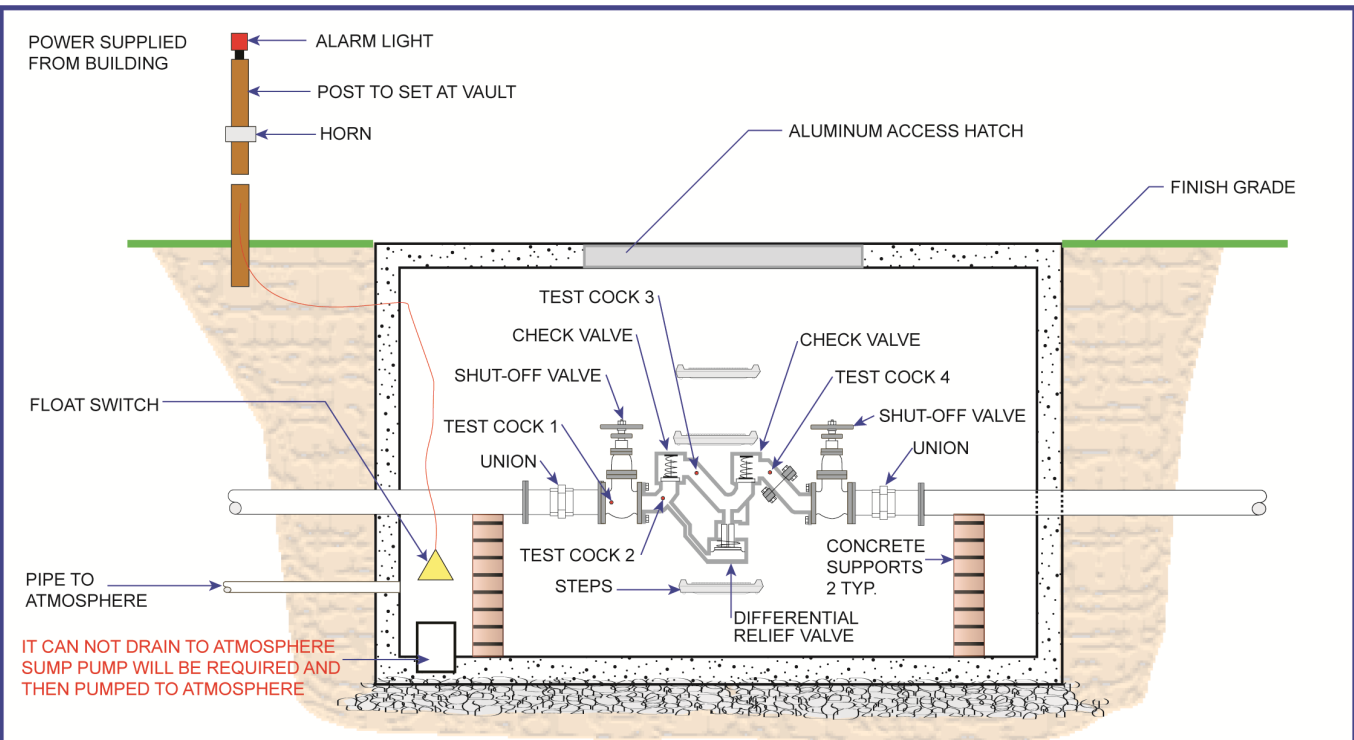

1. THE BACK-FLOW DEVICE SHALL BE LOCATED WITHIN 10' OF AND ON THE PROPERTY SIDE OF THE METER.
2. ALL INTERIOR AND EXTERIOR IRON SURFACES SHALL HAVE EPOXY COATINGS TO CONFORM WITH ANSI/AWWA C550, OR MANUFACTURED OF STAINLESS STEEL.
3. THE BACK-FLOW DEVICE SHALL HAVE 4 TEST COCKS WITH ONE INSTALLED ON THE CITY SIDE OF THE INLET GATE VALVE.
4. SHUT OFF VALVES SHALL BE RESILIENT SEATED GATE VALVES WITH FLANGED ENDS AND HAND-WHEEL.
5. ABOVE GROUND ENCLOSURE CAN BE USED, AS PER CITY SPECIFICATIONS.
6. A FOUR INCH GRAVITY FLOOR DRAIN SHALL BE PROVIDED OR A 2" SUMP PUMP INSTALLED IN A 12" SQUARE BY 12" DEEP SUMP BASIN.
7. VAULT TOPS SHALL BE ONE PIECE, REINFORCED CONCRETE (SEPARATE UNIT FROM THE VAULT) WITH ACCESS DOOR CAST IN. ACCESS DOOR TO BE 36" X 36" ALUMINUM WITH SPRINGS AND SLAM LOCK MECHANISM. ALL HARDWARE MANUFACTURED OF STAINLESS STEEL.
8. VAULT WALLS SHALL BE 6" PRE-CAST WALL SECTIONS, OR 8" BLOCK. IF LOCK WALLS ARE USED, COAT OUTSIDE OF WALL WITH THORO-SEAL OR EQUAL.
9. TANDEM BACK-FLOWS REQUIRED IF SERVING MULTIPLE USERS OR IF SERVICE CANNOT BE INTERRUPTED.

3/4" - 8"
**REDUCED PRESSURE BACK-FLOW
 PREVENTER BELOW GROUND**

	<p>STANDARD #302WB</p> <p>CITY OF CONOVER UTILITIES DEPARTMENT</p>	<p>TYPICAL DESIGN STANDARDS</p> <p>3/4" - 8"</p> <p>REDUCED PRESSURE BACK-FLOW PREVENTER BELOW GROUND</p>
---	---	---

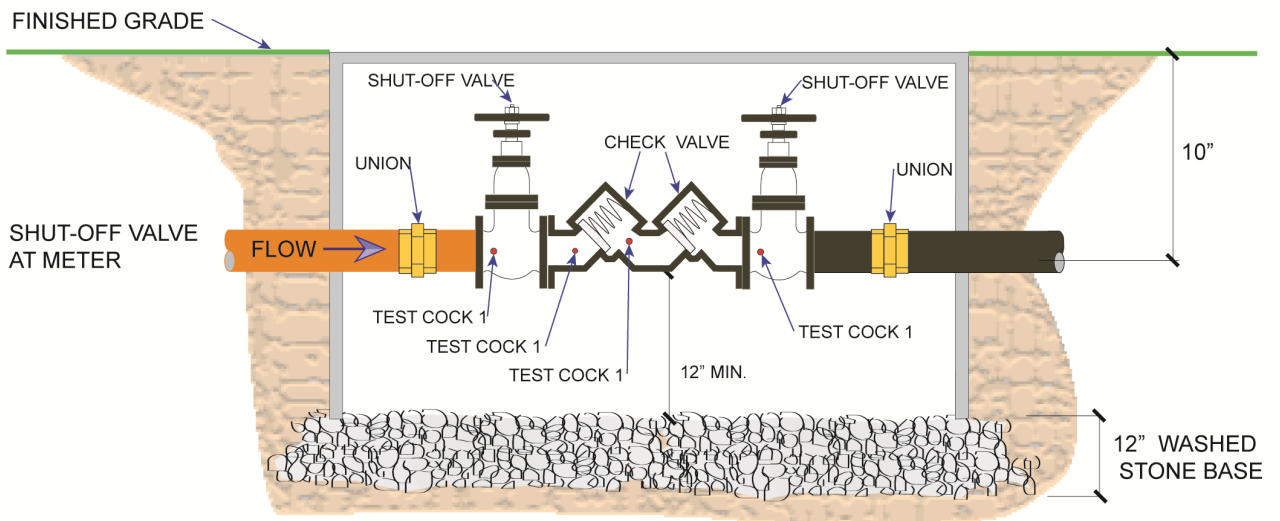

1. THE BACK-FLOW DEVICE SHALL BE LOCATED WITHIN 10' OF AND ON THE PROPERTY SIDE OF THE METER
2. THE UNIT SHALL BE PURCHASED AS AN ASSEMBLY INCLUDING 4 TEST COCKS WITH ONE ON THE CITY SIDE OF THE INLET BALL VALVE.
3. ALL DOUBLE CHECK VALVES MUST BE INSTALLED IN A HORIZONTAL POSITION.
4. DEVICES SHALL HAVE TWO RESILIENT SEAT BRONZE UNIONS ON THE OUTER SIDES OF THE SHUT OFF VALVES FOR REMOVAL OF THE DEVICE.
5. THE BOX SHALL BE
6. DRAIN REQUIRED IF INSTALLED IN PAVED AREA.
7. TANDEM BACK-FLOWS REQUIRED IF SERVING MULTIPLE USERS OR SERVICE CANNOT BE INTERRUPTED.
8. DITCH MUST REMAIN OPEN UNTIL BACK-FLOW IS INSPECTED BY CONOVER PUBLIC WORKS WATER DEPT.

SIZES 3/4" - 1"
DOUBLE CHECK VALVE ASSEMBLY



STANDARD # 303WB
CITY OF CONOVER
UTILITIES DEPARTMENT

TYPICAL DESIGN STANDARDS
DOUBLE CHECK VALVE ASSEMBLY
3/4" - 1"

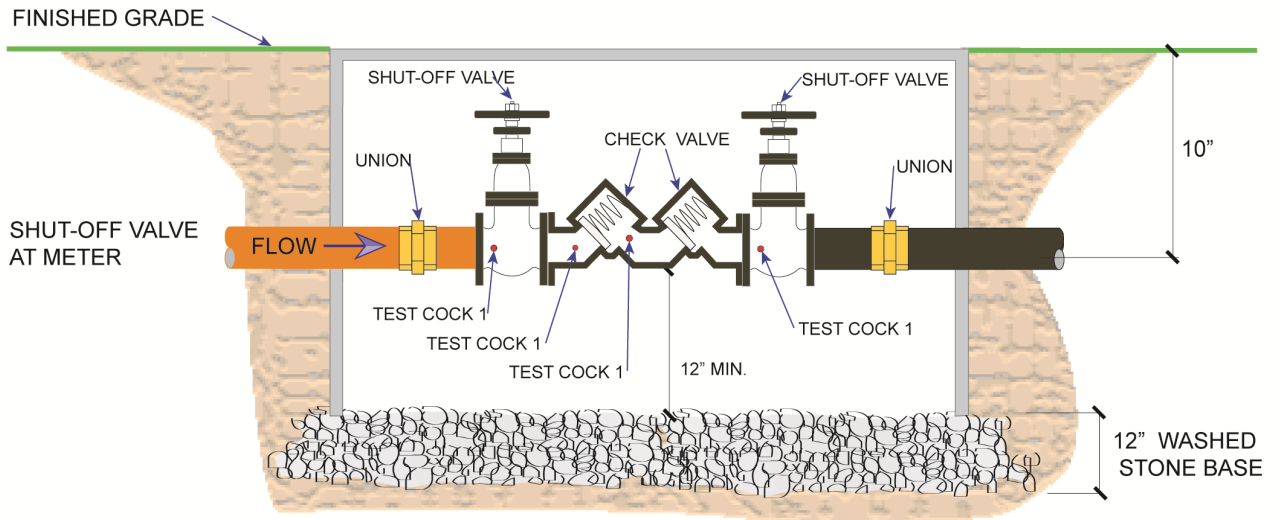

1. THE BACK-FLOW DEVICE SHALL BE LOCATED WITHIN 10' OF AND ON THE PROPERTY SIDE OF THE METER
2. THE UNIT SHALL BE PURCHASED AS AN ASSEMBLY INCLUDING 4 TEST COCKS WITH ONE ON THE CITY SIDE OF THE INLET BALL VALVE.
3. ALL DOUBLE CHECK VALVES MUST BE INSTALLED IN A HORIZONTAL POSITION.
4. DEVICES SHALL HAVE TWO RESILIENT SEAT BRONZE UNIONS ON THE OUTER SIDES OF THE SHUT OFF VALVES FOR REMOVAL OF THE DEVICE.
5. THE BOX SHALL BE
6. DRAIN REQUIRED IF INSTALLED IN PAVED AREA.
7. TANDEM BACK-FLOWS REQUIRED IF SERVING MULTIPLE USERS OR SERVICE CANNOT BE INTERRUPTED.
8. DITCH MUST REMAIN OPEN UNTIL BACK-FLOW IS INSPECTED BY CONOVER PUBLIC WORKS WATER DEPT.

SIZES 1 1/2" - 2"
DOUBLE CHECK VALVE ASSEMBLY



STANDARD # 304WB

CITY OF CONOVER
PUBLIC UTILITIES DEPARTMENT

TYPICAL DESIGN STANDARDS
DOUBLE CHECK VALVE ASSEMBLY
1 1/2" - 2"

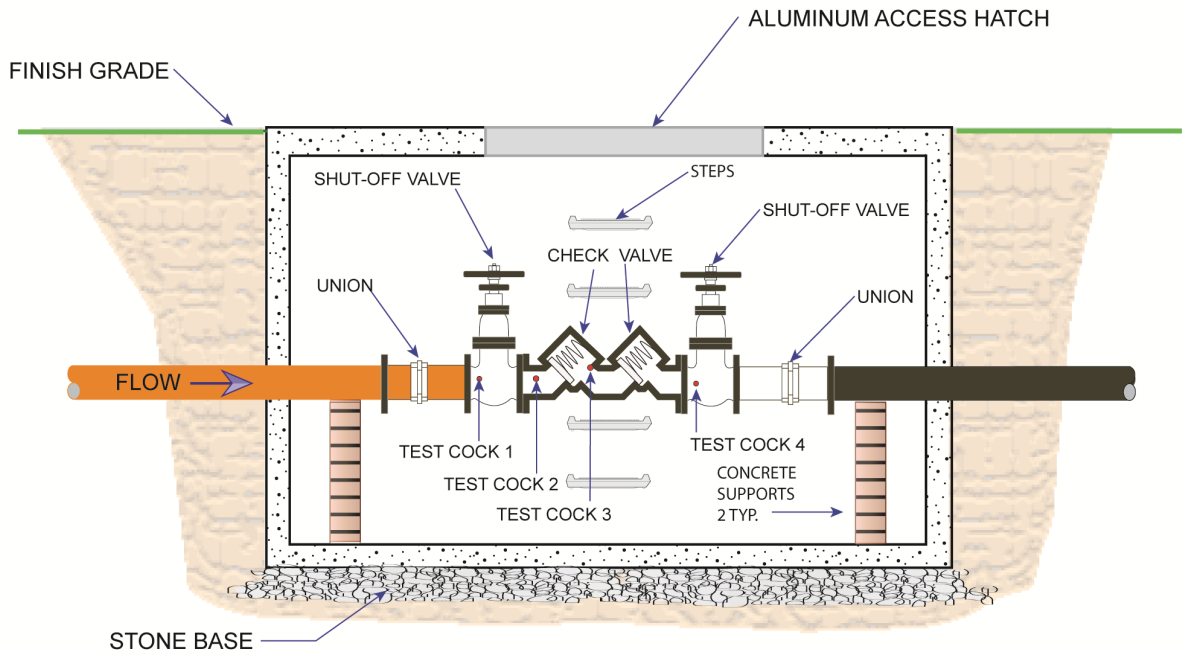

1. THE BACK-FLOW DEVICE SHALL BE LOCATED WITHIN 10' OF AND ON THE PROPERTY SIDE OF THE METER.
2. ALL INTERIOR AND EXTERIOR IRON SURFACES SHALL HAVE EPOXY COATINGS TO CONFORM WITH ANSI/AWWA C550, OR MANUFACTURED OF STAINLESS STEEL.
3. THE BACK-FLOW DEVICE SHALL HAVE 4 TEST COCKS WITH ONE INSTALLED ON THE CITY SIDE OF THE INLET GATE VALVE.
4. SHUT OFF VALVES SHALL BE RESILIENT SEATED GATE VALVES WITH FLANGED ENDS AND HAND-WHEEL.
5. ABOVE GROUND ENCLOSURE CAN BE USED, AS PER CITY SPECIFICATIONS.
6. A FOUR INCH GRAVITY FLOOR DRAIN SHALL BE PROVIDED OR A 2" SUMP PUMP INSTALLED IN A 12" SQUARE BY 12" DEEP SUM BASIN.
7. VAULT TOPS SHALL BE ONE PIECE, REINFORCED CONCRETE (SEPARATE UNIT FROM THE VAULT) WITH ACCESS DOOR CAST IN. ACCESS DOOR TO BE 36" X 36" ALUMINUM WITH SPRINGS AND SLAM LOCK MECHANISM. ALL HARDWARE MANUFACTURED OF STAINLESS STEEL.
8. VAULT WALLS SHALL BE 6" PRE-CAST WALL SECTIONS, OR 8" BLOCK. IF LOCK WALLS ARE USED, COAT OUTSIDE OF WALL WITH THORO-SEAL OR EQUAL.
9. TANDEM BACK-FLOWS REQUIRED IF SERVING MULTIPLE USERS OR IF SERVICE CANNOT BE INTERRUPTED.
10. ALL DOUBLE CHECK VALVES SHALL BE INSTALLED IN A HORIZONTAL POSITION, EXCEPT FOR THOSE UNITS APPROVED FOR VERTICAL INSTALLATION.

SIZES 3" - 8"
DOUBLE CHECK VALVE ASSEMBLY



STANDARD # 305WB

CITY OF CONOVER
PUBLIC UTILITIES DEPARTMENT

TYPICAL DESIGN STANDARDS
DOUBLE CHECK VALVE ASSEMBLY
3" - 8"

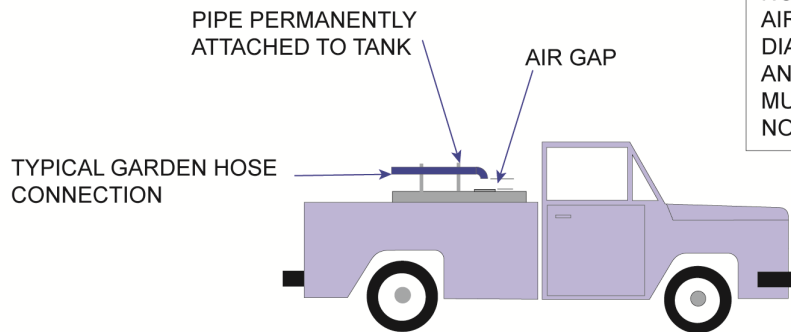
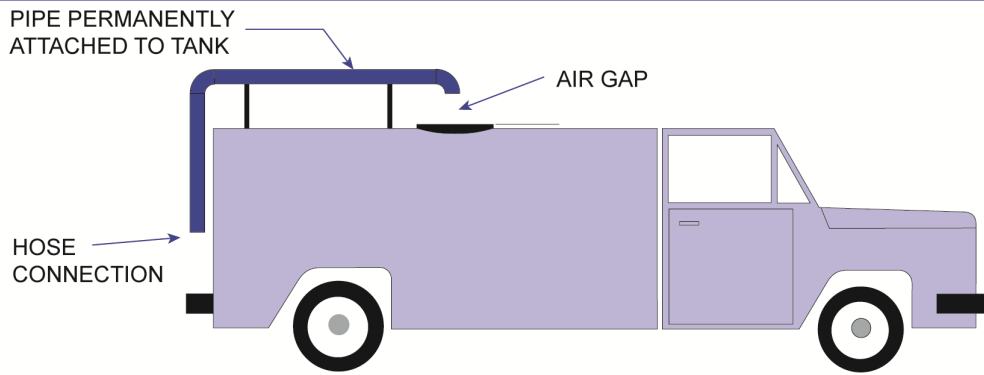

NOTE:
AIR GAP MUST BE MINIMUM OF 2X THE DIAMETER OF THE SUPPLY OUTLET AND NEVER LESS THAN 1". PIPING MUST BE "HARD-PIPED" FIRE HOSE IS NOT ACCEPTABLE.

FIGURE A - AIR GAP

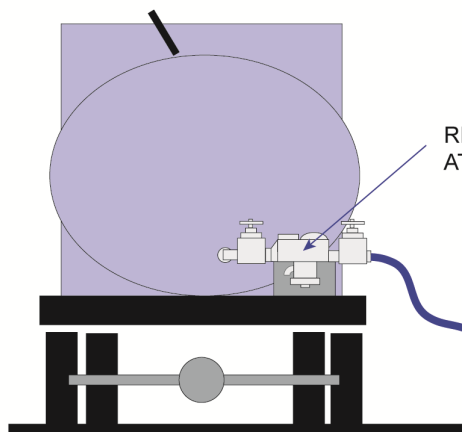

NOTE:
ALL TANKS SHALL SUPPLY A GALLON RESISTER METER OF SAME PIPE DIAMETER.

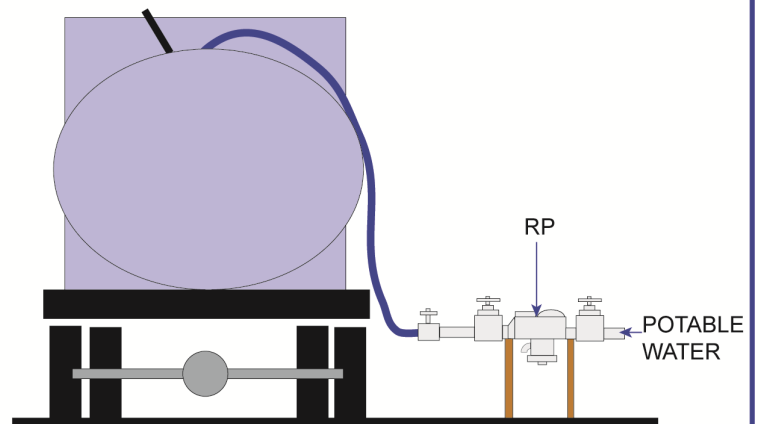

RP = A CITY OF CONOVER APPROVED REDUCE-PRESSURE PRINCIPLE ASSEMBLY.

FIGURE B - RP



STANDARD # 307WB

CITY OF CONOVER
PUBLIC UTILITIES DEPARTMENT

TYPICAL DESIGN STANDARDS
BACK-FLOW PREVENTION
TANKER TRUCKS
(AIR GAP & RP)

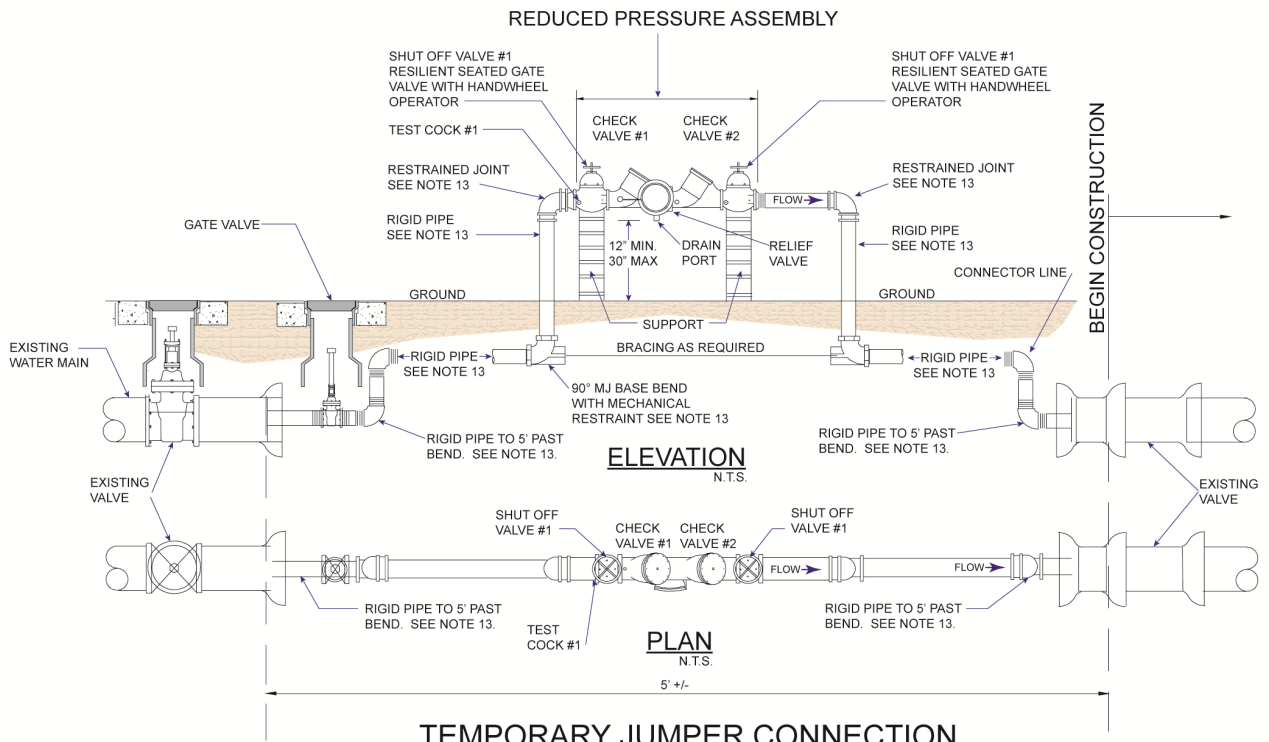

TEMPORARY JUMPER CONNECTION

NOTES:

1. INSTALL CONNECTOR LINE FROM EXISTING BLOW-OFF ASSEMBLY TO NEW MAIN FOR FILLING, TESTING, AND STERILIZING NEW MAIN.
2. CONNECTOR LINE TO BE ASSEMBLED WITH CHECK VALVE AND TO BE OPERATED INDEPENDENT OF EXISTING MAIN.
3. BLOCKING ON EXISTING LINE NOT TO BE DISTURBED.
4. FINAL CONNECTION TO EXISTING MAIN TO BE MAKE ONLY AFTER TOTAL PROJECT HAS BEEN ACCEPTED BY THE CITY OF CONOVER UTILITIES DEPARTMENT.
5. VALVES ON EXISTING SYSTEM TO BE OPERATED BY THE CITY OF CONOVER'S WATER DEPARTMENT STAFF ONLY.
6. ONLY ONE CONNECTION WILL BE ALLOWED BETWEEN THE EXISTING SYSTEM AND THE NEW CONSTRUCTION UNTIL TESTING AND DISINFECTION IS COMPLETE.
7. WATER IN REASONABLE AMOUNTS REQUIRED FOR AN IN CONNECTION WITH THE WORK TO BE PERFORMED WILL BE FURNISHED AT LOCATIONS AS APPROVED BY OWNER AT RATES SPECIFIED BY OWNER AND ACCORDANCE WITH THE FEDERAL, STATE AND LOCAL REGULATIONS, ORDINANCES AND POLICIES.
8. CONTRACTOR SHALL FURNISH NECESSARY PIPE, HOSE, REDUCED PRESSURE ZONE BACK FLOW DEVICE, AS APPROVED BY THE OWNER AND METER APPROVED BY OWNER, NOZZLES, AND TOOLS AND SHALL PERFORM ALL NECESSARY LABOR.
9. CONTRACTOR SHALL ENSURE THAT THE EQUIPMENT HAS BEEN INSPECTED BY AND APPROVED BY THE OWNER AND HAS OBTAINED THE APPLICABLE PERMITS AND CERTIFICATIONS PRIOR TO WATER CONNECTION.
10. CONTRACTOR SHALL MAKE ARRANGEMENTS WITH THE OWNER (WHO WILL FIX THE LOCATION, TIME, RATE, AND DURATION OF EACH WITHDRAWAL FROM THE DISTRIBUTION SYSTEM) AS TO THE AMOUNT OF WATER REQUIRED AND THE TIME WHEN THE WATER WILL BE NEEDED. UNNECESSARY WASTE OR WATER WILL NOT BE TOLERATED. IF CONTRACTOR WASTES WATER, AS DETERMINED BY OWNER, CONTRACTOR SHALL BE REQUIRED TO OBTAIN ALL REMAINING WATER NECESSARY FOR COMPLETION OF THE WORK MEASURED THROUGH A METER AND AT THE CONTRACTOR'S EXPENSE.
11. SPECIAL HYDRANT WRENCHES SHALL BE USED OR OPENING AND CLOSING FIRE HYDRANTS. IN NO CASE SHALL PIPE WRENCHES BE USED FOR THIS PURPOSE.
12. 6" TO 10" RP SHALL BE SUPPORTED WITH ADEQUATE SUPPORT PEDESTAL(S). SUPPORT PEDESTALS SHALL NO BLOCK RELIEF VALVE OR DRAIN PORT.
13. 2" TO 3" L-COPPER PIPE, 4" - 10" DIP. RESTRAINED JOINTS SHALL BE MEGA LUG RESTRAINTS OR APPROVED EQUAL.
14. TEST COCK SHALL BE UPSTREAM OF SHUT-OFF VALVE #1 AND IS PART OF THE APPROVED ASSEMBLY.

WATER MAIN SIZE	MIN. BACKFLOW DEVICE SIZE
6" OR 8"	2"
12"	4"
16"	6"
24"	8"



STANDARD #308WB

CITY OF CONOVER
PUBLIC UTILITIES DEPARTMENT

TYPICAL DESIGN STANDARDS
TEMPORARY JUMPER
CONNECTION